



Advanced Confined Space Safety Systems



**ADVANCED
HOIST SYSTEMS**



**PORTABLE FALL
ARREST SYSTEM**



**COUNTERWEIGHT
SYSTEMS**



**SIDE ENTRY
SYSTEM & TANK
PODS**



**POLE HOIST &
ACCESSORIES**



**DIGITAL & BASIC
SERIES WINCHES
& BRACKETS**



**TRIPODS &
BASIC HOIST
SYSTEMS**

FROM THE WORLDWIDE

EXPERTS IN FALL PROTECTION & RESCUE





Leaders in Confined Space Entry and Retrieval Fall Protection

Confined spaces can be below or above ground and are found on most job sites. Each year many workers are injured or killed while performing their daily work activities in confined spaces. Confined spaces have limited openings for entry and exit which complicates rescue/retrieval and other emergency response services. These often dangerous work environments are enclosed or partially enclosed and not designed or intended for long-term human occupancy. A restrictive confined space can represent health and safety risks to anyone who enters.

Capital Safety is the only global company that has been dedicated entirely to fall protection and confined space entry/retrieval and rescue. Our ISO 9001-2000 certification drives superior engineering, quality manufacturing and unparalleled customer service. Our design and engineering teams excel at finding the best way to keep workers totally safe and comfortable.

Combining experience and knowledge with state-of-the-art outdoor and indoor testing procedures, we produce the most technologically advanced safety equipment in the world. This equipment exceeds both national and international standards, including OSHA, ANSI, CSA, CE and AS/NZS. We call it "creating a higher standard of safety."

Your partner in safety

The highly trained professionals at Capital Safety educate, train and provide extensive long term support to ensure that all aspects of your fall protection program are successful. Choose DBI-SALA brand products—your one-stop for the most comprehensive collection of innovative fall protection products for any confined space application!



Providing a safe means for workers to access and work on all types of Confined Space Safety Systems.

- Confined Space Fall Protection Safety Systems2**
- ABC's of Fall Protection3**
- Advanced Hoist Systems 4-13**
- Counterweight Systems14-15**
- Davit Arm Bags & Accessories 16**
- Basic Hoist Systems 17**
- Pole Hoist & Accessories 18**
- Tank Pods 19**
- Tripods20-21**
- Side Entry System22-23**
- Portable Fall Arrest System24-25**
- Winches & Brackets26-29**
- Training & Consulting30**
- Capital Safety on the Web31**
- Confidence at Height32**



DBI-SALA & PROTECTA offers a complete array of passive and active fall arrest systems. The basics of every personal fall arrest system can be described as the ABC's of fall arrest.

A-Anchorage

Anchorage means a secure point of attachment (structure) for the fall arrest system. The type of anchorage varies with the application, the job being performed, the type of installation and the structure available. The anchorage connector provides a means of attaching the system to the anchorage (structure).



B-Body Support

Full body harnesses provide a connection point on the worker for the personal fall arrest system. Depending on the application, they can be used as part of a system to protect the worker from falling and to limit the extent of potential injury in case of a fall.



C-Connectors

Connectors are devices used to connect the worker's full body harness to the anchorage system. Connectors include lanyards, snap hooks, carabiners, deceleration devices and specialty systems such as self retracting lifelines, ladder climbing systems, vertical lifelines and rope grabs.



D-Descent/Rescue

Rescue and retrieval of a fallen worker is a required component of any Fall Protection Program.



ADVANCED HOIST SYSTEMS



The Advanced Series Hoist Systems are designed for manhole and confined space entry/retrieval applications.

These units are constructed of lightweight materials including high-strength aluminum. The Davit pivots for ease of rescue and has a limited adjustment for overhead clearance restrictions. The lower base adjusts to fit most standard entries. Many other bases are available. Options include lower masts to match overall height requirements.



Advanced 5-Piece Hoist System

Model #
8518000

Description
Includes 12"-29" (305 mm - 737 mm) adjustable offset upper mast (8518001), 33" (838 mm) lightweight lower mast (8518002), and 3-piece lightweight base (8518005).

Note: Winch not included.

Weight: 100 lbs (45.5 kg)



Advanced 5-Piece Hoist System

Model #
8518040

Description
Includes 31" - 42" (787 mm - 1067 mm) adjustable offset upper mast (8518006), 33" (838 mm) lightweight lower mast (8518002), and 3-piece lightweight base (8518008). Includes winch mount brackets.

Note: Winch not included.

Weight: 137.5 lbs (62.3 kg)

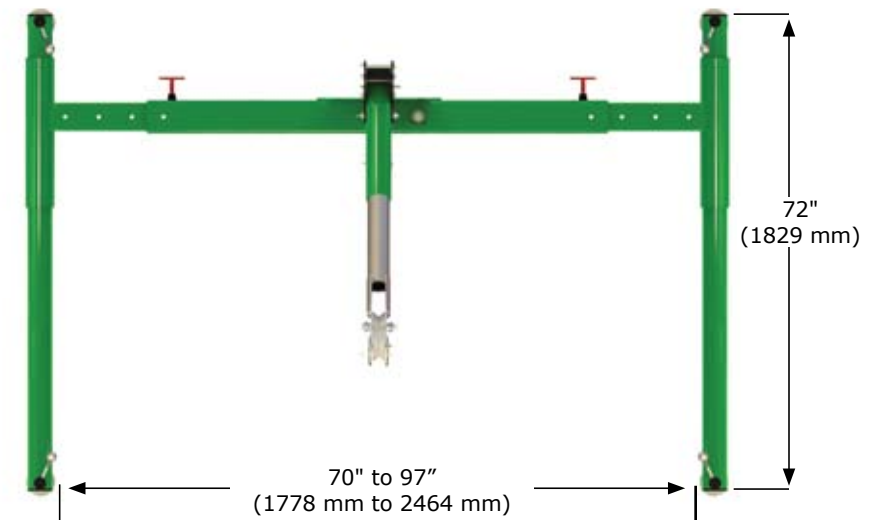
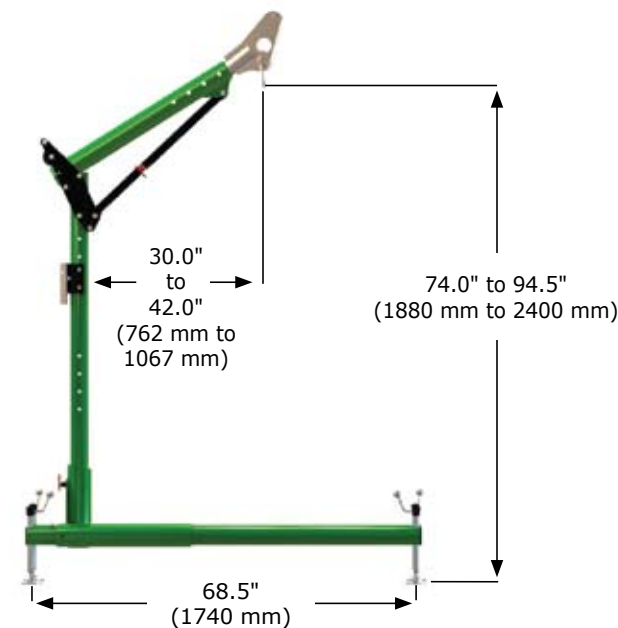
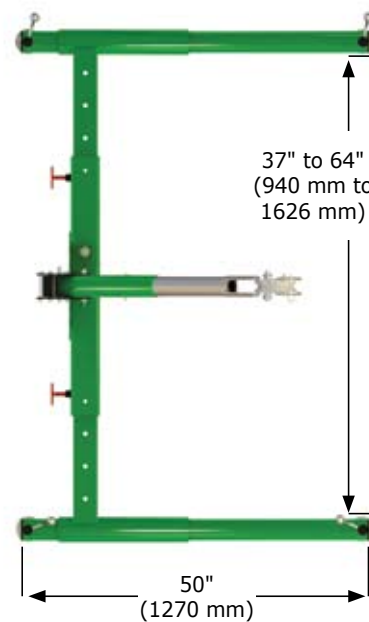
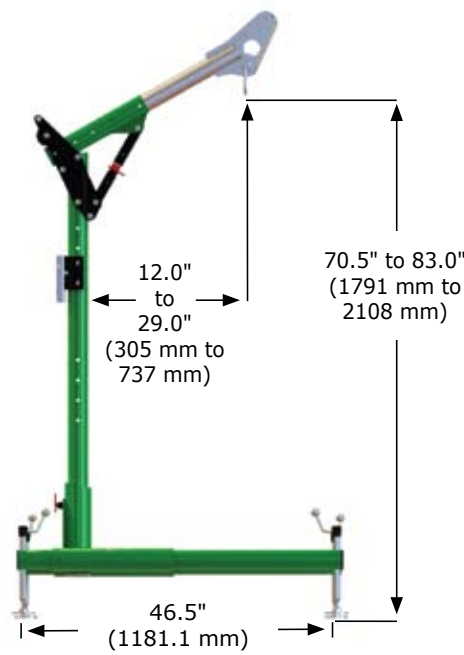



ADVANCED DAVIT ARM SYSTEM & COMPONENTS



Variable Offset Davits are designed for use where multiple offset masts are required. The Variable Offset Masts may be equipped with front mounted and/or back mounted winches or SRL's and feature a 5000 lb. (2272 kg) capacity anchor point for fall arrest anchorage. For applications with overhead clearance restrictions, the adjustable height of the Variable Offset Masts can eliminate the need for custom length masts and mast extensions. The addition of the quick-release pin allows for easy collapsibility and transport

Advanced Davit Arm Systems



- 1 - FALL ARREST ANCHORAGE**
Davits feature a 5000 lb (2268 kg) anchor point for fall arrest anchorage.
- 2 - ADJUSTABLE HEIGHT**
Eliminates the need for custom length masts and extensions.
- 3 - WINCH OPTIONS**
Davits can be equipped with back mounted winches or SRL's with retrieval capabilities.
- 4 - LOWER MAST EXTENSIONS**
Allow the user to increase the overall anchorage height of the system.
- 5 - BASE OPTIONS**
Several portable and fixed base options are available for complete versatility.

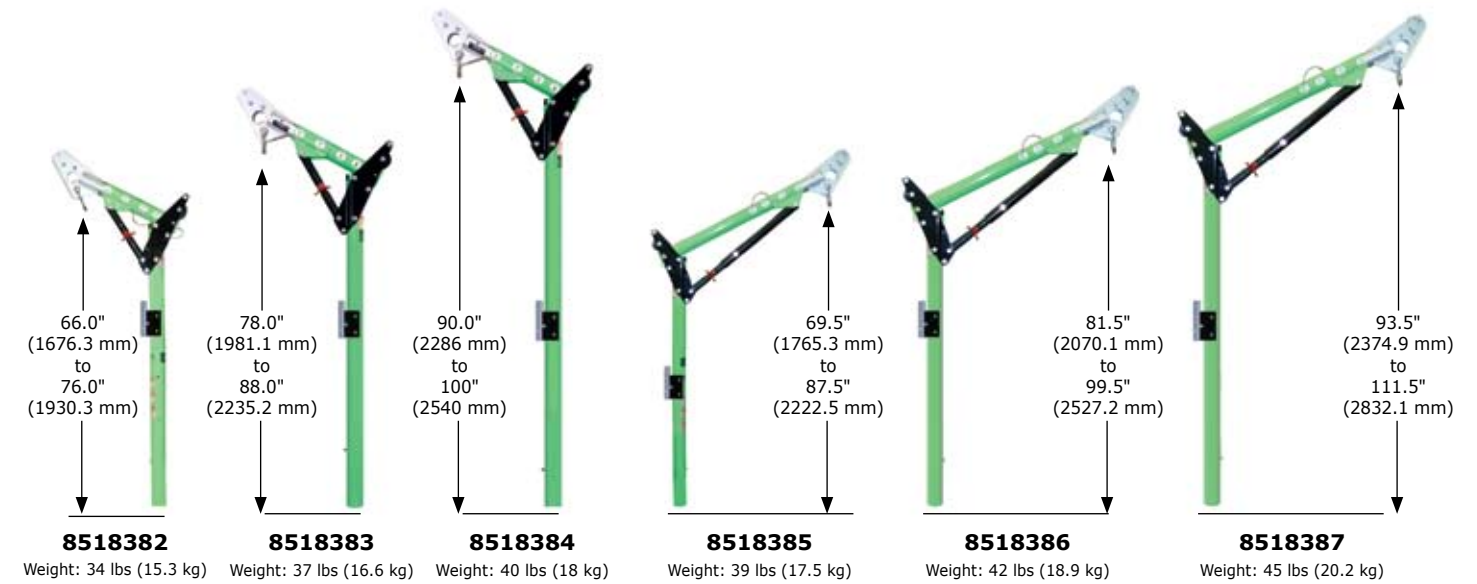

ADVANCED ONE PIECE ADJUSTABLE OFFSET DAVITS

Model #	Description
8518382	One Piece Adjustable Offset Mast 12" - 29" (305 mm - 737 mm), Anchor Point Height 66" - 76" (1676 mm - 1930.3 mm)
8518383	One Piece Adjustable Offset Mast 12" - 29" (305 mm - 737 mm), Anchor Point Height 78" - 88" (1981.1 mm - 2235.2 mm)
8518384	One Piece Adjustable Offset Mast 12" - 29" (305 mm - 737 mm), Anchor Point Height 90" - 100" (2286 mm - 2540 mm)
8518385	One Piece Adjustable Offset Mast 30" - 42" (762 mm - 1067 mm), Anchor Point Height 69.5" - 87.5" (1765.3 mm - 2222.5 mm)
8518386	One Piece Adjustable Offset Mast 30" - 42" (762 mm - 1067 mm), Anchor Point Height 81.5" - 99.5" (2070.1 mm - 2527.2 mm)
8518387	One Piece Adjustable Offset Mast 30" - 42" (762 mm - 1067 mm), Anchor Point Height 93.5" - 111.5" (2374.9 mm - 2832.1 mm)

ADVANCED UPPER & LOWER MASTS

Masts come standard with one set of winch mount brackets to accommodate a DBI-SALA winch or SRL. Additional brackets are available.

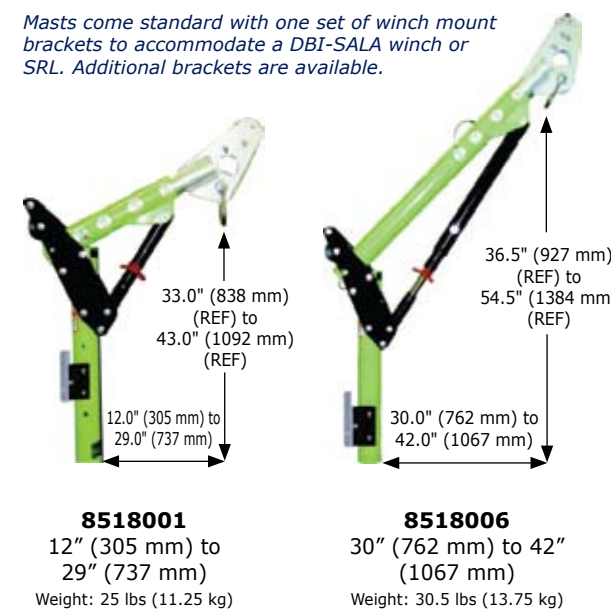

ADVANCED LOWER MASTS & EXTENSIONS

Working length lower mast/extensions for use only with Advanced Series Davit. Combine up to 2 lower mast extensions to increase the anchorage height. *Custom lengths are available. Please call.

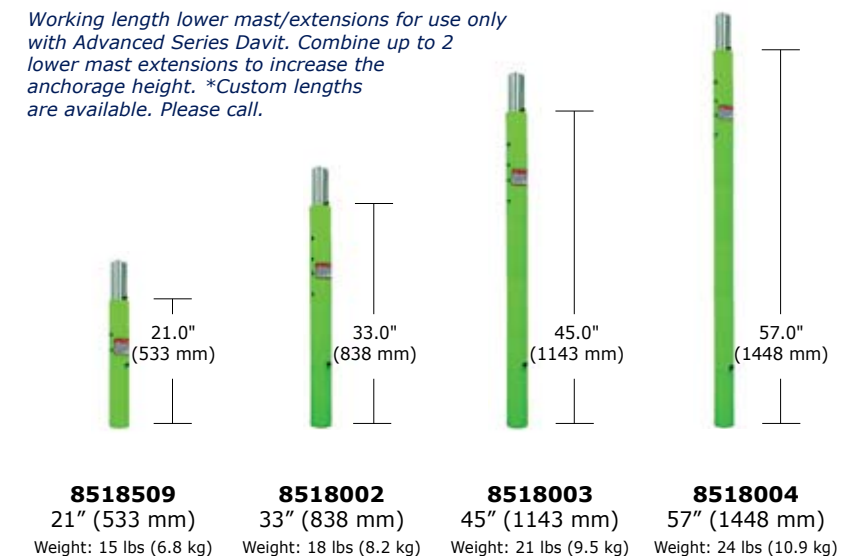

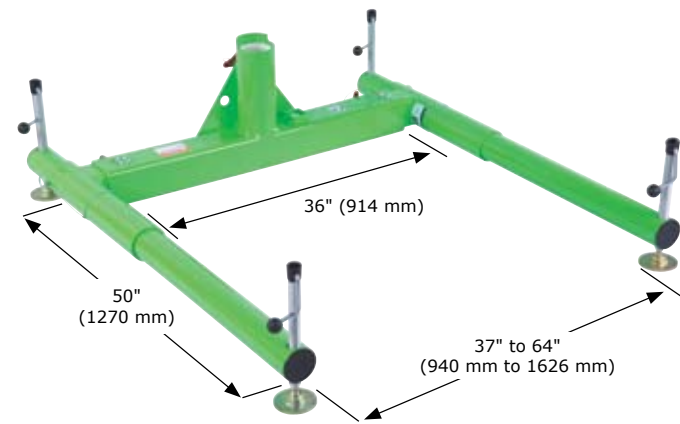

Advanced 3-Piece Expandable Base For Max. 29" (737 mm) Offset

Model #	Description	Weight
8518005	Advanced 3-Piece Expandable Base For Max 29" (737 mm) Offset	60 lbs (27.3 kg)



Model #	Description
8510501	Manhole Collar - Designed for applications involving frequent setups over similarly sized access openings. Lightweight, powder-coated aluminum construction for portability. Comes with PVC sleeve liner. Custom sizes and shapes available. Please call for more information.
8510520	19.5" (495 mm) Manhole Collar for use on manways 20" - 22" (508 mm - 558 mm) in diameter
8510457	21.5" (546 mm) Manhole Collar for use on manways 22" - 24" (558 mm - 609 mm) in diameter
8510163	23.5" (597 mm) Manhole Collar for use on manways 24" - 26" (609 mm - 660 mm) in diameter
8510633	25.5" (647 mm) Manhole Collar for use on manways 26" - 28" (660 mm - 711 mm) in diameter
8510632	27.5" (698.5 mm) Manhole Collar for use on manways 28" - 30" (711 mm - 762 mm) in diameter
8510546	29.5" (749 mm) Manhole Collar for use on manways 30" - 32" (762 mm - 812 mm) in diameter
8512994	33.5" (851 mm) Manhole Collar for use on manways 34" - 36" (863 mm - 914 mm) in diameter

Weight: 35-60 lbs (16-27 kg)

ADVANCED PORTABLE BASES



Advanced Portable and Fixed Bases work with a variety of Advanced Davit Arm and Mast Extensions. Portable bases are ideal for work areas where frequent set-up and tear down is required. Fixed bases mount to existing structures.

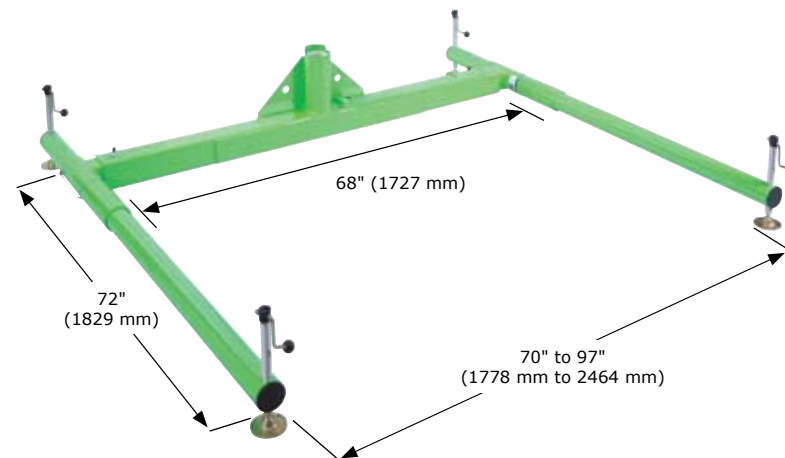

Advanced 3-Piece Expandable Base For Max. 48" (1219 mm) Offset

Model #	Description	Weight
8518008	Advanced 3-Piece Expandable Base For Max 48" (1219 mm) Offset	92 lbs (41.8 kg)



Model #	Description
8510323	Barrel Mount Sleeve with 3.5" (89 mm) Opening Mild steel construction. Eight independent clamping screws allow temporary installations over edges of shoring cans, walls and other structures. Comes with PVC inner liner. Custom fit openings available.

Weight: 36.5 lbs (16.6 kg)

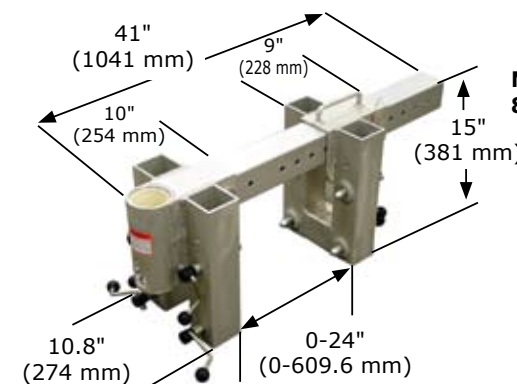

Model #	Description
8512285	Adjustable Barrel Mount Sleeve Designed for shoring, wall and parapet applications where frequent set-up over varying wall thicknesses is required. Standard unit accommodates wall thicknesses up to a maximum of 24" (609.6 mm), with shorter or longer adjustment tubes available on request. Anodized, welded aluminum with zinc plated steel hardware for lightweight durability. Comes with inner sleeve. Custom sizes are available.

Weight: 56 lbs (25.5 kg)

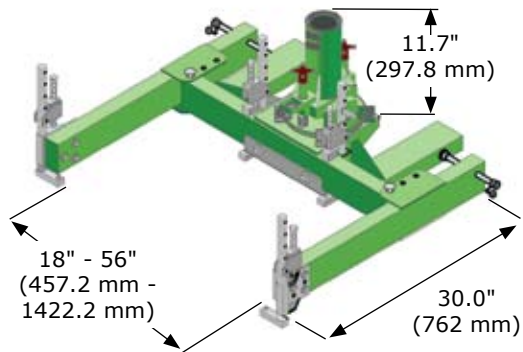

Model #
8519377

Description
External Tank Cover

Comes with Adjustable Sleeve 82 lbs (37.2 kg) Assembly (8511232). Used on manways with a flange structure that the unit may be secured onto. This collar can clamp onto 6" (152 mm) max thick flange.

Weight: 82 lbs (37.2 kg)

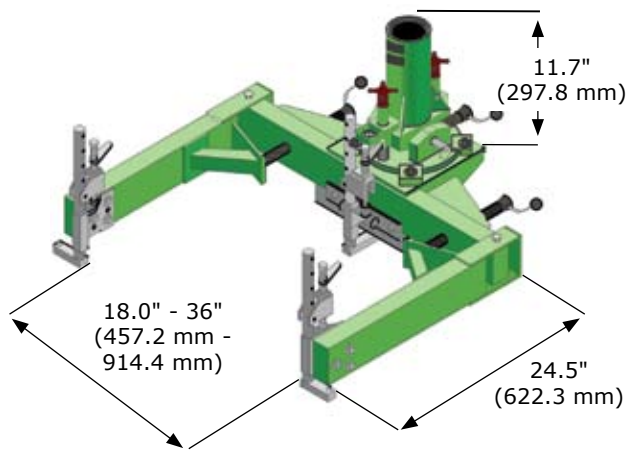

Model #
8519378

Description
Internal Tank Cover

Comes with Adjustable Sleeve Assembly (8511232). Used on manways with a structure that the unit may be secured onto. This collar may be used with sleeve assemblies and masts or for vertical entries.

Weight: 61 lbs (27.7 kg)

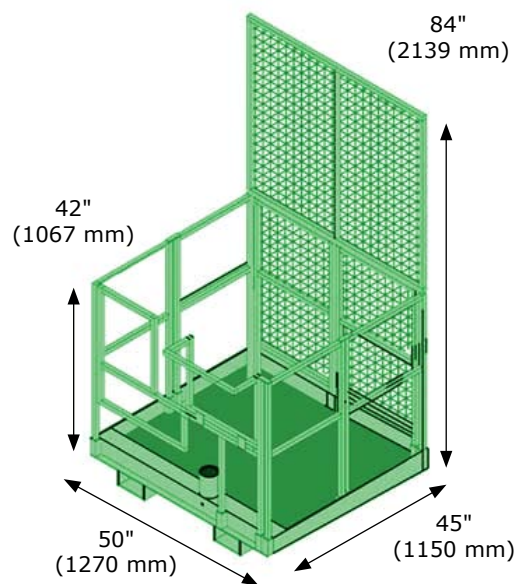

Model #
8510568

Description
Forklift Basket

Designed to convert your forklift truck into a versatile work platform, confined space safety and fall-arrest system. By adding various accessories to the forklift basket a wide variety of confined space entry/retrieval and fall-arrest situations can be handled with ease. Lightweight modular aluminum construction and tool-less assembly makes set-up, transport and storage convenient and efficient. Durable powder-coated finish with anti-slip finish on walking surfaces. Includes spring-loaded gate.

Weight: 215 lbs (98 kg)

Advanced Vehicle Hitch Mount Sleeve

The Vehicle Hitch Mount Sleeve is designed to install into a 2" (51 mm) hitch receiver on an attendant vehicle to provide a portable anchor point for confined space entry/retrieval, rescue and fall-arrest systems. Various sockets, extensions and accessories are available to allow use of the sleeve in a multitude of situations.

Model #
8510140

Description
Vehicle Hitch Mount Sleeve

Assembly for a maximum 29" (736.6 mm) Offset Mast

Weight: 57 lbs (25.8 kg)

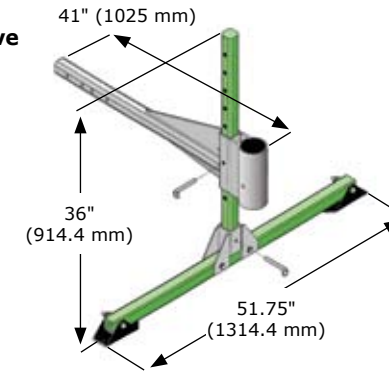

Model #
8514461

Description
Vehicle Hitch Mount Sleeve

Assembly for a maximum 48" (1219.2 mm) Offset Mast

Weight: 62 lbs (28.1 kg)

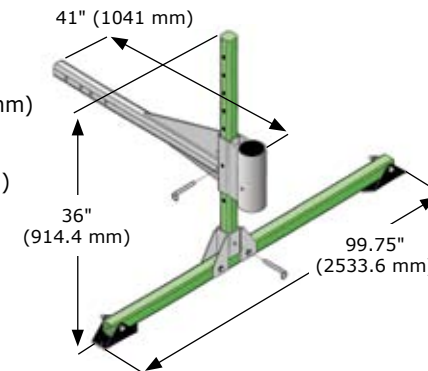

Model #

Description

Vehicle Hitch Sleeve Extensions - Extensions are available in a variety of lengths. A maximum of one extension can be used with a hitch mount and a bumper attachment.



8514503
8512829
8511384

2' (0.61 m) Sleeve Extension
4' (1.21 m) Sleeve Extension
6' (1.83 m) Sleeve Extension

Weight: 17 lbs (7.7 kg)
Weight: 27.8 lbs (12.6 kg)
Weight: 39 lbs (17.6 kg)

Bumper Attachment Options

Model #
8511401

Description

Universal Joint Assembly - The Universal Joint Assembly installs between the standard model 8510140 Hitch Mount Sleeve or extensions and the attendant's vehicle to compensate for uneven ground conditions at the site.
Weight: 10 lbs (4.5 kg)

8520886

Universal Hitch Ball Coupler
Weight: 16 lbs (7.6 kg)



ADVANCED VEHICLE HITCH MOUNT SLEEVE





ADVANCED FIXED BASES



Advanced Portable and Fixed Bases work with a variety of Advanced Davit Arm and Mast Extensions. Portable bases are ideal for work areas where frequent set-up and tear down is required. Fixed bases mount to existing structures.

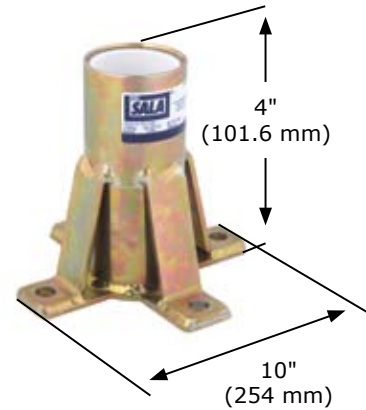

Model # 8516190
Description
Floor Mount Sleeve
 Zinc-plated mild steel construction. Mounts to horizontal concrete or steel structure. Comes with PVC sleeve liner.

Weight: 13 lbs (5.9 kg)

Model # 8518347
Description
Floor Mount Sleeve
 304 Stainless Steel
Weight: 13 lbs (5.9 kg)

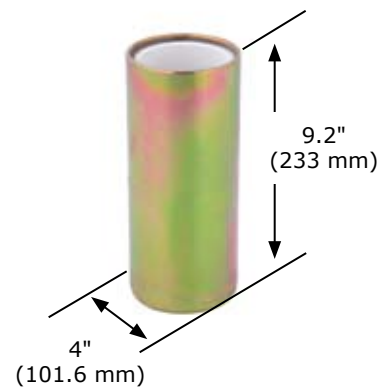

Model # 8510109
Description
Core Mount Sleeve
 Zinc-plated mild steel construction. Designed for slip-in installation into 4" (101.6 mm) core hole in concrete or in an existing steel structure. Comes with PVC sleeve liner.

Weight: 8 lbs (3.6 kg)

Model # 8510110
Description
Core Mount Sleeve
 Stainless Steel
Weight: 8 lbs (3.6 kg)

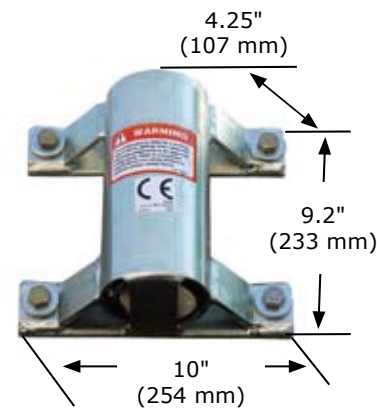

Model # 8518348
Description
Wall Mount Sleeve
 304 Stainless Steel construction. Compact design creates minimum intrusion into work space. Mounts to vertical concrete or steel structures. Comes with PVC sleeve liner.

Model # 8516191
Description
Wall Mount Sleeve
 Zinc-plated mild steel construction.
Weight: 12 lbs (5.5 kg)



Model # 8510311
Description
Flush Floor Mount Sleeve
 Mild steel construction. Comes with pins for fresh concrete and cast-in-place concrete anchors for new construction or renovation. Flush mount design allows passage of traffic and eliminates trip hazards when not in use. Comes with PVC sleeve liner.

Weight: 21 lbs (9.5 kg)

Model # 8512828
Description
Flush Floor Mount Sleeve
 Stainless steel construction. Comes with pins for fresh concrete installation.

Weight: 21 lbs (9.5 kg)

Model # 8510316
Description
Flush Floor Mount Sleeve
 Mild Steel construction. Recessed fastener pockets allow for bolt-in installation into existing concrete or steel structure. Flush mount design allows passage of traffic and eliminates trip hazards when not in use. Comes with PVC sleeve liner.

Weight: 21 lbs (9.5 kg)

Model # 8512827
Description
Flush Floor Mount Sleeve
 Stainless steel construction for existing concrete installation.

Weight: 21 lbs (9.5 kg)



Model # 8512831
Description
Center Mount Sleeve
 Zinc Plated Mild Steel construction. Mounts to existing concrete. Comes with PVC sleeve liner.

Weight: 13 lbs (5.9 kg)

Model # 8516563
Description
Center Mount Sleeve
 Stainless Steel

Weight: 13 lbs (5.9 kg)

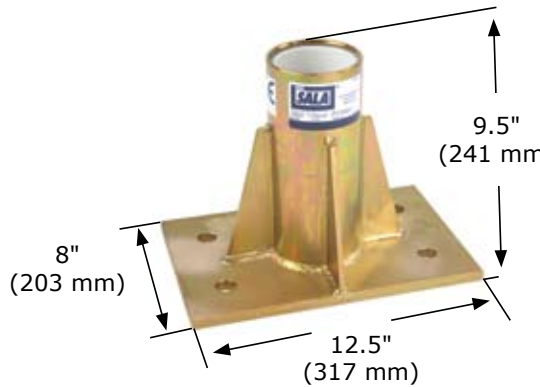

Model # 8515162
Description
Deck Mount Sleeve
 Designed to slip into a 4" (101.6 mm) hole in existing flooring. Flush mount design allows passage of traffic and eliminates trip hazards when not in use. Comes with all necessary hardware. Mounts to thicknesses from 1/4" to 2.0" (6.4 mm - 50.8 mm) max.

Weight: 17 lbs (7.7 kg)

Model # 8515834
Description
Deck Mount Sleeve
 Stainless Steel. Includes plastic stopper & mounting hardware.

Weight: 17 lbs (7.7 kg)

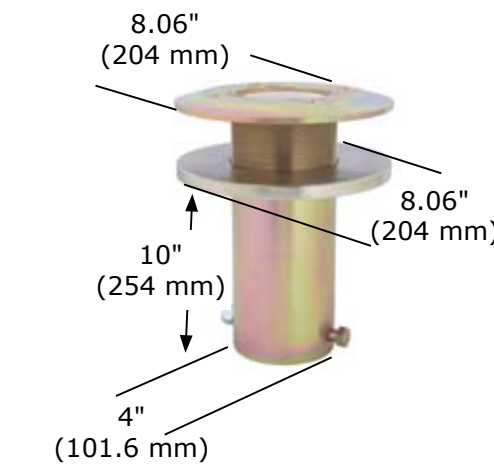



Advanced Counterweight System

Model #
8512894 **Description**
Counterweight System Base
w/Pole Leg Assembly.

Weight: 199 lbs (90.2 kg)

Note: Winch and davit not included.



Model #
8514496 **Description**
Counterweight System Base w/Screw Leg Assembly
Use this base assembly with the Advanced Catwalk Clamp to secure to the underside of elevated walkways, catwalks and mezzanines. This option offers a flexible means of tank entry into challenging areas. Weight plates sold separately.

Weight: 192 lbs (87.1 kg)

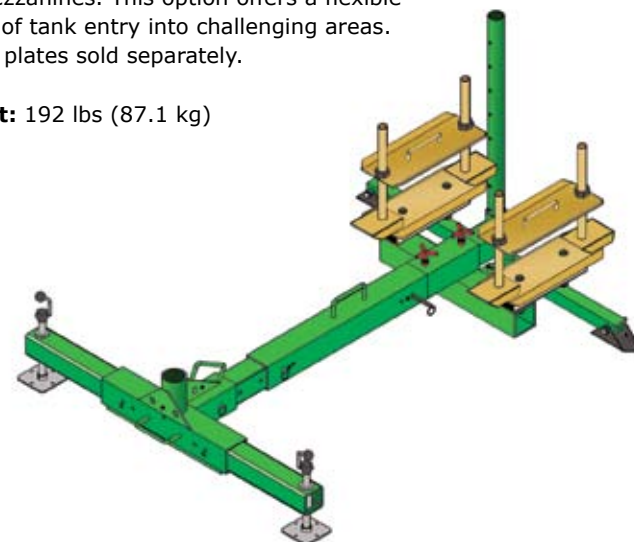

Anchorage Options

The **Counterweight Base** assembles and disassembles without tools and can be fitted with a variety of anchorage and davit arm options for complete versatility. The Pole Leg Assembly system is ideal for use with the Counterweight Rack and Vehicle Counterweight Wheel Pad to adjust the height of the system to accommodate a leading edge. The Screw Leg Assembly System is ideal for use with the Counterweight Cart and Catwalk Clamp.

Custom application development is available. Please call for more information.

- Model #**
8513593 **Description**
Center Section Base
For Counterweight System
Weight: 22 lbs (9.9 kg)
- 8511111** **36" (914 mm) Inner Extension Tube**
For the Counterweight Base
Weight: 10 lbs (4.5 kg)
- 8515071** **31" (787 mm) Outer Extension Tube**
For the Counterweight Base
Weight: 12 lbs (5.4 kg)
- 8513153** **Adjustable Height Pole Leg Section**
To accommodate maximum 29" (736 mm) offset. Requires two.
Weight: 6 lbs (2.7 kg)
- 8514418** **Adjustable Height Pole Leg Section**
To accommodate maximum 48" (1219 mm) offset. Requires two.
Weight: 8 lbs (3.6 kg)
- 8512900** **Leg Section with Screw Legs**
To accommodate maximum 0" - 29" (736 mm) offset. Requires two.
Weight: 12 lbs (5.4 kg)
- 8520887** **Leg Section with Screw Legs**
To accommodate maximum 30" - 48" (762 mm - 1219 mm) offset. Requires two.
Weight: 14 lbs (6.3 kg)
- 8520867** **Counterweight Cart**
Offers a portable solution to move your counterweight easily & effectively in areas throughout a plant on level ground. Weight plates sold separately.
Weight: 300 lbs (136 kg)
- 8513515** **Counterweight Rack Assembly**
Accommodates a maximum of twenty-nine 50 lb (22.5 kg) weight-lifting plates for 1450 lbs (658 kg) of anchorage. Weight plates sold separately.
Weight: 88 lbs (39.9 kg)
- 8520866** **Catwalk Clamp**
Designed to secure to the underside of elevated walkways, catwalks & mezzanines. This option offers a flexible means of tank entry into challenging areas. The 8515071 Outer Tube is not required when using the catwalk clamp. Custom inner tube lengths available for different width walkways. Please call.
Weight: 26 lbs (11.8 kg)
- 8513618** **Vehicle Counterweight System Wheel Pad**
Allows counter balance of the Counterweight System with an attendant vehicle.
Weight: 40 lbs (18.4 kg)

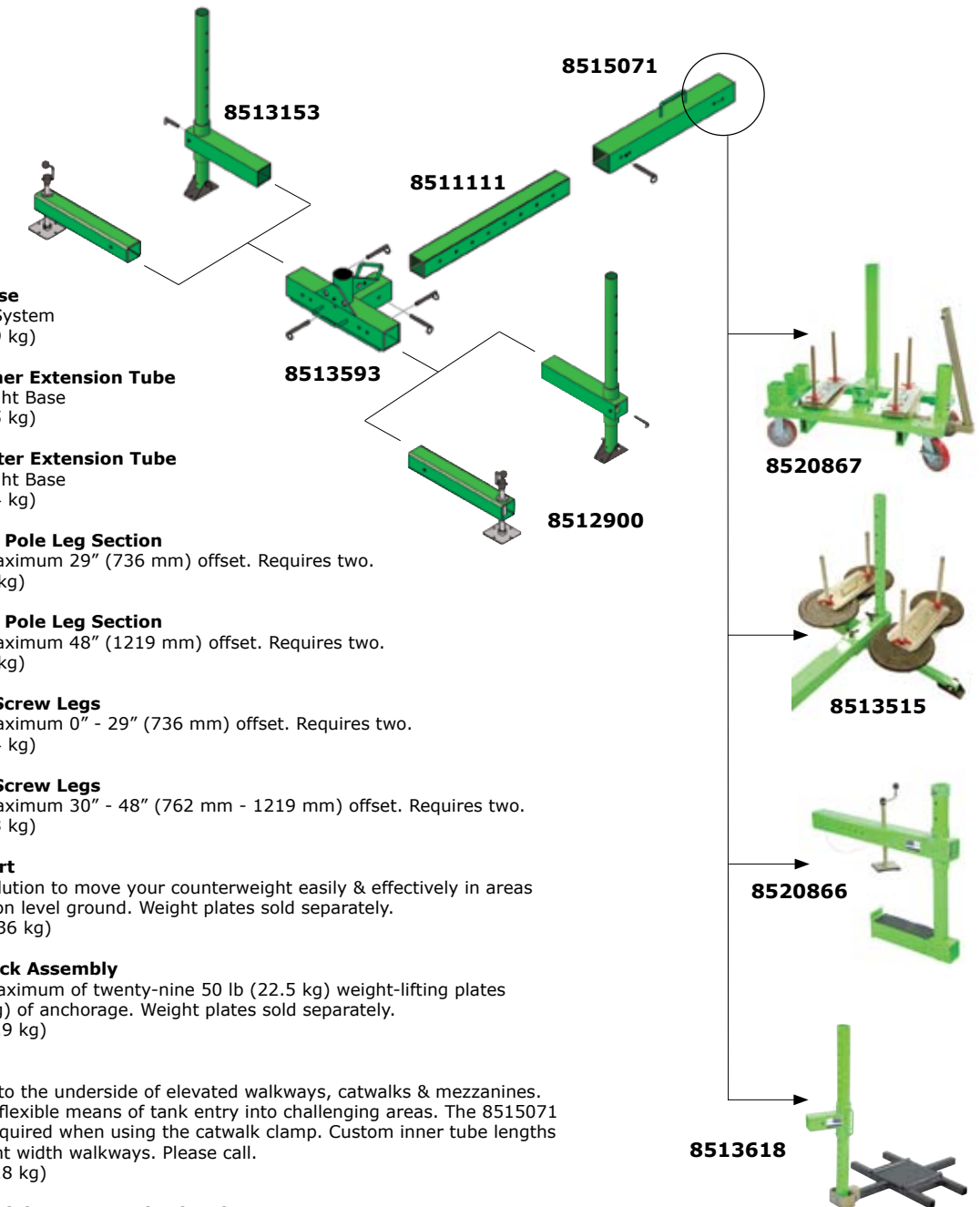

ADVANCED COUNTERWEIGHT SYSTEMS



The Advanced Counterweight System is composed of a central base unit to accommodate a variety of anchoring options, positioning and adjustment legs, and extension assemblies. Anchoring options include a weight rack for counter balanced applications, and a wheel pad assembly to allow counter balance of the unit with an attendant vehicle.

NOTE: Individual weight plates sold separately.



DAVIT ARM BAGS & ACCESSORIES



These essential accessories make transportation and storage of your Advanced Hoist Systems and components simple and easy.



Model #
8518270

Description
Advanced 5 Piece Equipment Cart
Transport the Advanced 5 Piece System with maximum ease over smooth or rough terrain. Ideal for tight storage situations.

Weight: 40 lbs (8.9 kg)



8513330

Model #
8513330

Description
Carrying Bag with protective plastic liner for Advanced Davit arms (8518383, 8518384, 8518386 and 8518387).

8513564

Carrying Bags for 12" - 29" (305 mm - 737 mm) offset mast. lower mast w/protective plastic liner.

8518513

Set of 2 Carrying Bags for Model 8518000 5 Piece Hoist systems.

8513565

Carrying Bags for 3 Piece Base (8510732) c/w protective plastic liner.



8513565

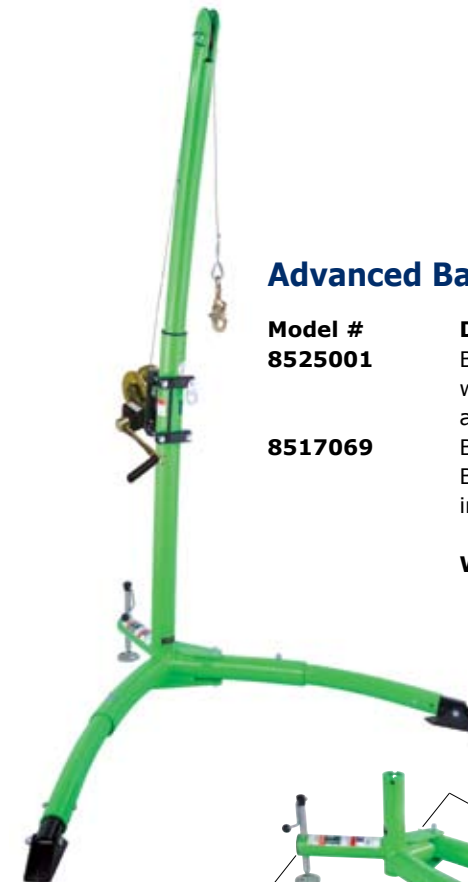

Advanced Basic Hoist System

Model #
8525001

Description
Basic Hoist System, incl. folding hoist, winch x 50 ft. (15.2 m) galvanized and brackets.

8517069

Basic Hoist Package w/Folding Basic Base & winch bracket. Winch not included.

Weight: 58 lbs (26.3 kg) Hoist only

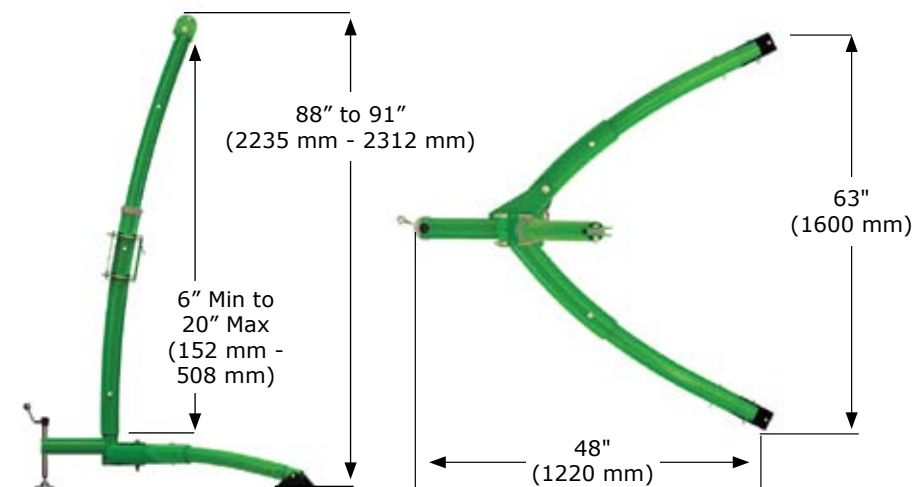
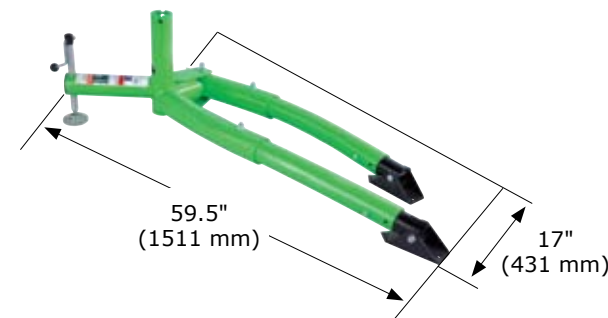

ADVANCED BASIC HOIST



The Advanced Basic Hoist is the most efficient and economical confined space entry/retrieval alternative to a tripod. This lightweight aluminum structure assembles and adjusts without tools. The Advanced Basic Hoist features a collapsible base to reduce storage and transport space. A standard tie-off point provides a convenient 5000 lb (2268 kg) anchor point for fall arrest devices where required. All hardware is zinc plated for corrosion resistance.

NOTE: First-time setup requires some tools and assembly.



Advanced 4' - 7' (1.2 m - 2.13 m) Extendable Pole Hoist

- Model # 8510409** Description 4' - 7' (1.2 m - 2.13 m) Extendable Pole Hoist, swivel head & hardware. Includes winch bracket.
- 8516303** Description 4' - 7' (1.2 m - 2.13 m) Extendable Pole Hoist, swivel head & stainless steel hardware. Includes winch bracket.
- Weight:** 12 lbs (5.4 kg)



8513700
Winch and SRL not included.

POLE HOIST SYSTEMS & ACCESSORIES

Advanced 6' - 10' (1.8 m - 3.05 m) Extendable Pole Hoist

- Model # 8510476** Description 6' - 10' (1.8 m - 3.05 m) Extendable Pole Hoist, swivel head & hardware. Includes winch bracket.
- 8520869** Description 6' - 10' (1.8 m - 3.05 m) Extendable Pole Hoist, swivel head & stainless steel hardware. Includes winch bracket.
- Weight:** 14 lbs (6.4 kg)



8515982

- Model # 8513700** Description Advanced Tank Pod, designed to secure to 5/8" (15.8 mm) studs
- 8515982** Wheel Cart for Tank Pod
- 8515981** Stainless Steel Multiple Angle 3/4" (19 mm) Weld-on Studs (3 pack)
- 8515299** Mounting Stud Extension Adaptor (3 pack) 1/2" NC - 5/8" NC (12.7 mm - 15.8 mm)
- 8515300** Mounting Stud Extension Adaptor (3 pack) 5/8" NC - 5/8" NC (15.8 mm - 15.8 mm)
- 8515301** Mounting Stud Extension Adaptor (3 pack) 3/4" NC - 5/8" NC (19 mm - 15.8 mm)
- 8516012** Tank Pod Mast Extension

Accessory Options

- Model # 8511235** Description T-bar leg assembly (required)
- 8516442** Description T-bar leg assembly w/stainless steel hardware and fasteners
- 8513329** Description Carrying Bag for 4' - 7' (1.2 m - 2.13 m) Pole Hoist
- 8513330** Description Carrying Bag for 6' - 10' (1.8 m - 3.05 m) Pole Hoist



8515981



8516012



8515299



ADVANCED TANK POD SYSTEM & ACCESSORIES

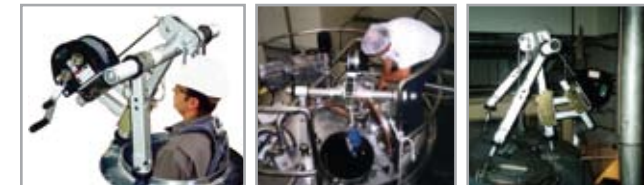

The Advanced Tank Pod is designed to mount to tank manways with existing hardware for securing hatch covers. It mounts to manway flanges on bolt circle diameters from 19" to 36" (482.5 mm - 914.4 mm), with studs from 1/2" NC to 3/4" (12.7 mm - 19 mm) NC. Three independently adjustable legs accommodate flange inclinations to a maximum of 45 degrees. The unit can be set up in an overhead clearance of only 25" (635 mm). The Tank Pod can be fitted with a variety of winches, ladder systems and fall arrest devices to meet any application requirement.



ADVANCED TRIPODS



Advanced Tripods are constructed of lightweight tubular aluminum with a rugged steel head assembly. The UCT-300 Tripod can be combined with up to three pulleys to accommodate a variety of winches and fall arrest devices to meet a wide range of confined space entry/retrieval and rescue requirements. Pulleys are mounted on top of the head assembly to provide extra overhead clearance in tight situations. Quick release pins positively locate components at all adjustment points for tool-less setup and adjustment.



ADVANCED UCT-1000 10' (3.05 m) TRIPOD
With adjustable locking legs, safety chains, top pulley & winch bracket.
8513159

Weight: 68 lbs (30.8 kg)

Note: Winch not included.



ADVANCED UCT-300 7' (2.13 m) TRIPOD 8513158

Weight: 84.6 lbs (38.4 kg)

Note: Winch not included.

ADVANCED 7' (2.13 m) ALUMINUM TRIPOD 8000000

Weight: 47 lbs (21.15 kg)

Note: Winch not included.



Model #	Description
8513158	Advanced UCT-300 7' (2.13 m) Tripod with adjustable locking legs, safety chains, top pulley and winch bracket.
8513159	Advanced UCT-300 10' (3.05 m) Tripod with adjustable locking legs, safety chains, top pulley and winch bracket.
8000000	Advanced 7' (2.13 m) Aluminum Tripod with adjustable locking legs, safety chains, top pulley and winch bracket.
8000010	Advanced 9' (2.74 m) Aluminum Tripod with adjustable locking legs, safety chains, top pulley and winch bracket.

CANTILEVER RESCUE SYSTEM KIT

The Cantilever Rescue System Kit quickly and easily converts your UCT-1000 10' (3.05 m) tripod into a versatile piece of equipment for confined space entry/retrieval and high-angle rescue operations over roof edges, parapets, guard rails, cliffs, bridges or other situations. Using the rigid wheel pad supplied with the kit, the cantilever system may be anchored with a service vehicle's weight, weight rack or with a single anchor point.

8512297 **Weight:** 29.7 lbs (13.5 kg)

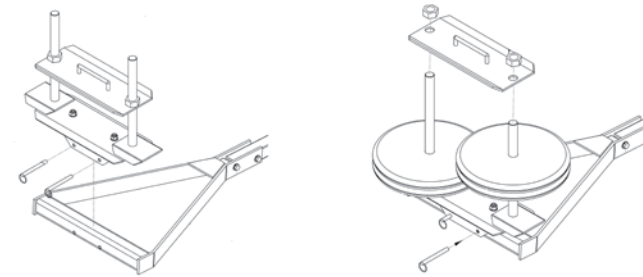

CANTILEVER KIT WEIGHT RACK FOR USE WITH THE UCT-1000 TRIPOD

Use the weight rack in conjunction with the UCT-1000 tripod and cantilever system for counter balanced confined space entry/retrieval and rescue operations over roof edges, parapets, guard rails, cliffs, bridges or other situations. 50 lb (22.7 kg) weight plates sold separately.

8515631

Weight: 36 lbs (16.3 kg)



TOP MOUNT PULLEY FOR CANTILEVER SYSTEM

Converts the system to handle both a winch & SRL.

8515150

Weight: 3.4 lbs (1.5 kg)

Advanced Tripod Accessories

Model #	Description
8513329	Carrying bag with protective plastic liner for 7' (2.13 m) tripod
8513330	Carrying bag with protective plastic liner for 10' (3.05 m) tripod



WINCH MOUNTING BRACKET FOR UCT-1000 TRIPOD

Attaches to the leg tube with quick-release pins for toolless set-up and adjustment.

8512292

Weight: 5.2 lbs (2.4 kg)



WINCH MOUNTING BRACKET FOR UCT-300 TRIPOD

Attaches to the leg tube with quick-release pins for toolless set-up and adjustment.

8510224

Weight: 3 lbs (1.4 kg)



TOP PULLEY ASSEMBLY FOR UCT TRIPODS

Pulleys are mounted on top of the head assembly to provide extra overhead clearance in tight situations.

8512293

Weight: 1.6 lbs (.73 kg)



ADVANCED SIDE ENTRY SYSTEM



The Advanced Side Entry System is designed for confined space entry/retrieval and rescue operations involving horizontal entries with vertical positioning or retrieval required inside the space. The Advanced Side Entry System may be used with the model 8511231 External Adjustable Tank Collar for adaptation to different manways. It may also be used with a permanently mounted base and extension post (8514803). The Side Entry System features flexible setup options and a fully articulating boom system. It is fully adaptable to an infinite number of manway designs and surrounding configurations.



Note: Winch & base not included.

Advanced Side Entry System for Permanent Mount Applications

MODEL #	DESCRIPTION
8514803	Arm Assembly, Side Entry System Weight: 44 lbs (19.9 kg)
8514796	Support Post: 38" to 53.5" (965 mm - 1359 mm) Weight: 35 lbs (15.8 kg)
8510100	15" (381 mm) Mast Extension (shown) Weight: 16 lbs (7.2 kg)
8510101	24" (610 mm) Mast Extension Weight: 19 lbs (8.6 kg)
8510102	36" (914 mm) Mast Extension Weight: 23 lbs (10.4 kg)
8510103	48" (1219 mm) Mast Extension Weight: 27 lbs (12.2 kg)

NOTE: Shown with Advanced Floor Mount Fixed Base and Digital 100 Series Winch, not included.

Fixed Base Options



The **Advanced Side Entry System for Permanent Mount** applications can be used with a variety of fixed bases. Please see page 12-13 for more information.



Note: Winch not included.

Advanced Side Entry System for Portable Mount Applications

MODEL #	DESCRIPTION
8511231	External Adjustable Tank Collar, w/tie bar assemblies, used to fit outside of manway Weight: 52 lbs (23.5 kg)
8511233	Side Entry System Package for use with external adjustable tank collar or permanently mounted bases Weight: 69 lbs (31.3 kg)
8514909	Large Winch Mount Bracket Weight: 2 lbs (.91 kg)
8511832	Small Winch Mount Bracket Weight: 2 lbs (.91 kg)

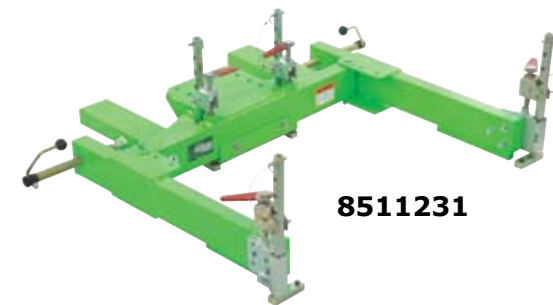

8511231



8511233



8511832



PORTABLE FALL ARREST SYSTEM



The Advanced Portable Fall Arrest Post is specifically designed for use on top of transformers or other types of vertical platforms with potential fall hazards. It's compact and lightweight design of only 38 lbs (17.2 kg) makes the post very easy to transport and put in place. The system features 3 independent swivel anchor points. They can rotate 360 degrees, offering freedom of mobility for up to 3 workers with self-retracting lifelines or fixed length lanyards.

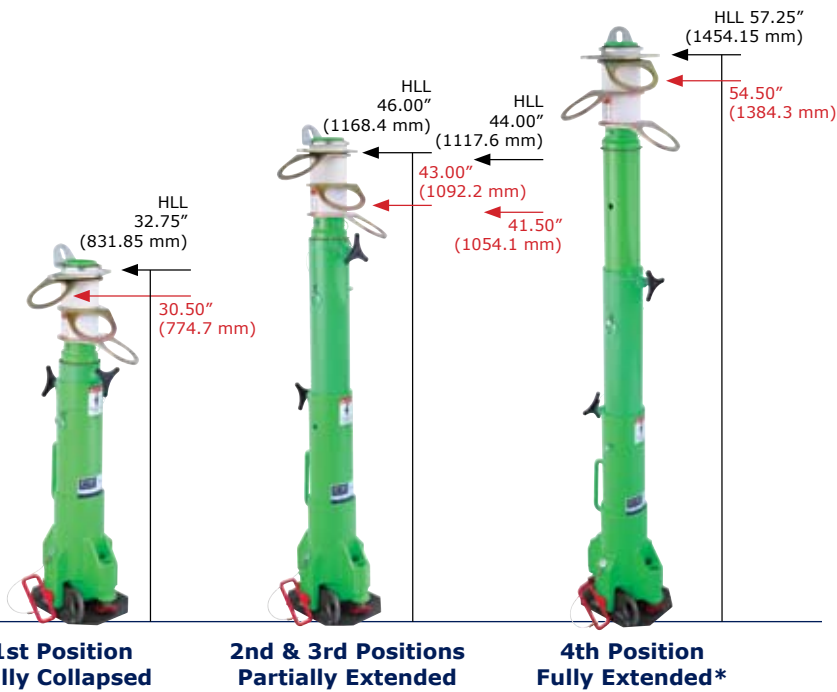

The Portable Fall Arrest System has 3 telescopic working heights ranging from 30.5" (774 mm) 43" (1092 mm), all the way up to 54.5" (1384 mm). This decreases a worker's fall distance and increase the overall work area. **NOTE: The Rescue Davit Arm works in the 2nd and 4th positions only.*

MODEL #	DESCRIPTION
8516691	Advanced Portable Fall Arrest System
8517565	Heavy Duty Black Carrying/Storage Bag for Advanced Series PFAS Anchor Post or Davit Arm.

PLATFORM

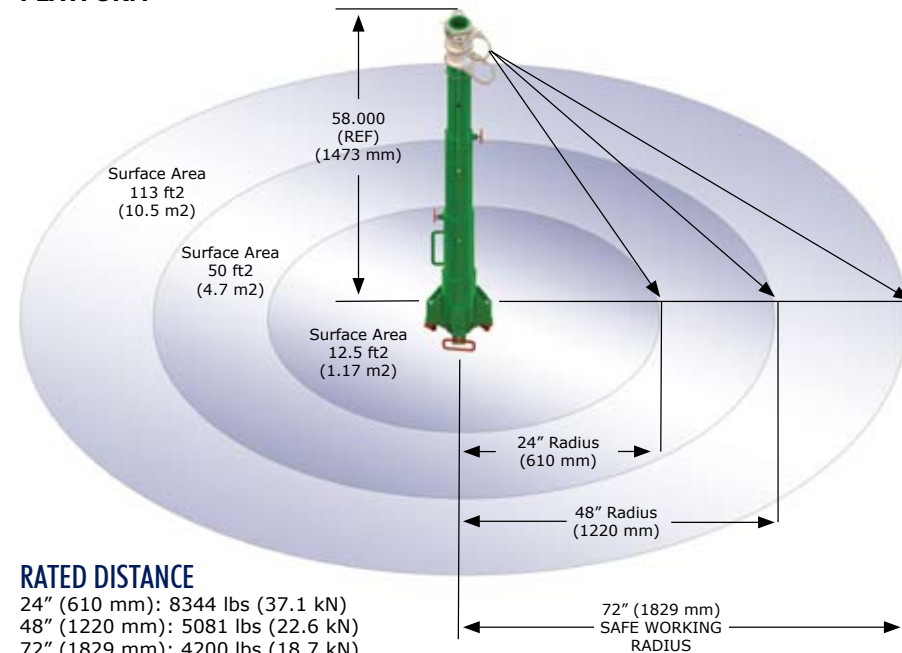

Portable Fall Arrest System Options

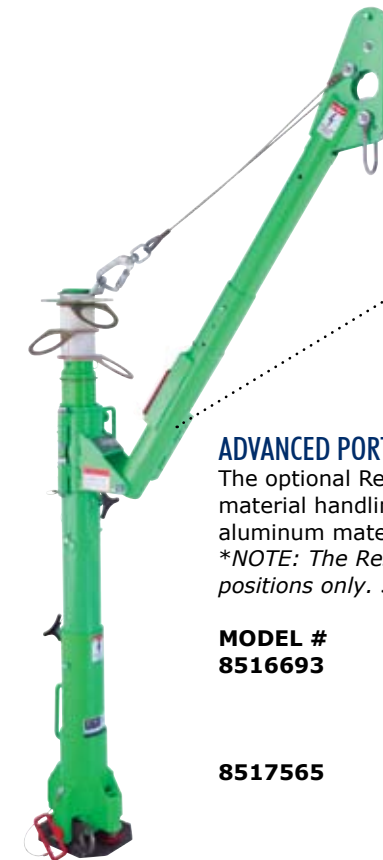

Rescue Davit Arm can be equipped with a variety of winches and SRLs.

ADVANCED PORTABLE FALL ARREST POST RESCUE DAVIT ARM
 The optional Rescue Davit Arm assembles easily to address material handling or rescue needs. It's made with lightweight aluminum materials for easy transportation and setup. **NOTE: The Rescue Davit Arm works in the 2nd and 4th positions only. See previous page.*

MODEL #	DESCRIPTION
8516693	Advanced Portable Fall Arrest Post Rescue Davit Arm. Weight: 20.5 lbs (9.3 kg)

8517565	Heavy-duty carrying bag for davit arm only.
---------	---

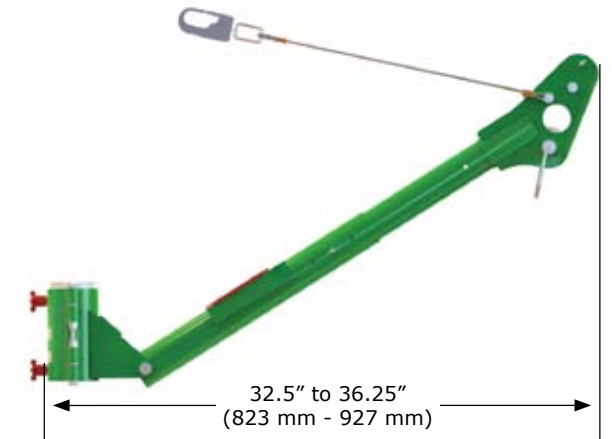

PRO-ANCHOR STYLE POST
 Provides a different anchorage option.
8517362
 Weight: 20.5 lbs (9.3 kg)

PRO-ANCHOR PLATE
 For use with the Pro-Anchor Style Post.
8512322
 Weight: 5.8 lbs (2.6 kg)



BARE STEEL UNI-ANCHOR WITH TIE-OFF ANCHORS
 For use in closed environments without chemical or moisture exposure.
8517412
 Weight: 11.6 lbs (5.3 kg)



WELD-ON MOUNTING PLATE
 Unplated mild steel construction.
8510816
 Weight: 11.6 lbs (5.3 kg)

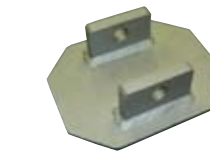

UNI-ANCHOR I-BEAM BASE
 For connecting the PFAS to an I-Beam.
8516997
 Weight: 56 lbs (25.5 kg)



14' (4.2 m) UNI-ANCHOR FALL ARREST POST
 The 14' (4.2 m) Uni-Anchor Fall Arrest Post mounts using Uni-Anchor plates and extends up to 14' (4.2 m) to provide a 1-man-rated fall arrest anchor point.
8516996
 Weight: 71 lbs (32.3 kg)



14" (356 mm) ANCHOR POST EXTENSION
 Allows for tie-off of one worker at an increased height of 68.5" (1740 mm).
8516692
 Weight: 5 lbs (2.2 kg)

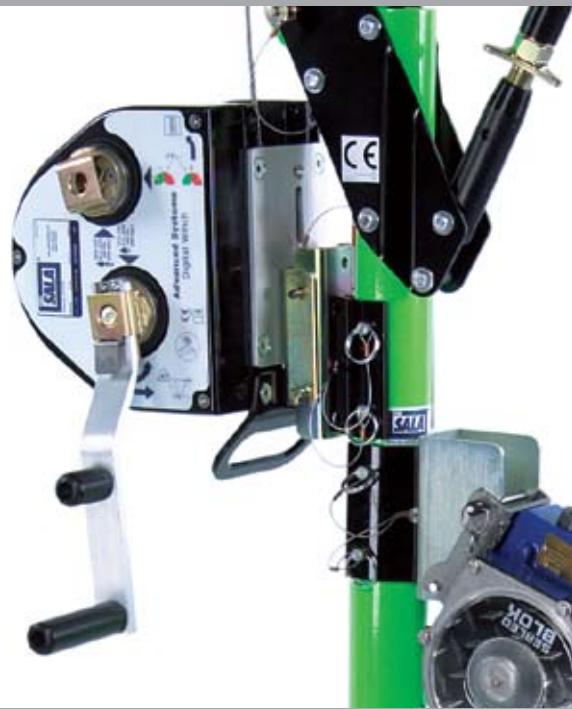

ADVANCED DIGITAL SERIES WINCH

MAN RATED

For raising, lowering or supporting personnel. Working load 450 lbs (204 kg). Designed specifically for confined space entry/retrieval.

DIGITAL USAGE INDICATOR

The exclusive "digital usage indicator" system counts the revolutions of the drum to determine service intervals. Additional standard features include a braking system with 3 independent working pawls, centrifugal back-up brake, carrying handle and cable retainer spring.

COMPLIANT HARDWARE

Double locking swivel safety snaps standard on all cables. Sealed bearings at all contact points. All hardware is Zinc plated. All components are zinc-plated steel or anodized aluminum.

TRIPLE REDUNDANT BRAKING MECHANISM

A friction brake is engaged by a minimum of 5 lbs (2 kg). Brake pad wear indicator monitors the condition of the braking mechanism, which features an inertial (centrifugal) safety back up brake.

Advanced Digital Series Winches are rated for a maximum working load of 450 lbs (204 kg) with an 11:1 safety factor. This winch has two cranking speeds capable of retrieval/descent from 13 ft/min (4 m/min) to 30 ft/min (9 m/min).

Advanced Digital Winches are available in 3 standard sizes. It accommodates various diameters of cables up to 3/8" (9.5 mm) and ropes up to 5/8" (15.9 mm). All cable/rope assemblies come with a double locking swivel snap hook with overload indicator.

ADVANCED DIGITAL 100 SERIES 2 SPEED WINCH W/ REMOVABLE HANDLE

This Advanced Digital 100 Series Winch includes a removable aluminum crank handle to utilize both our 9:1 and 4:1 drives. These two drives offer the capability of retrieval/descent at average speeds from 13 ft/min (4 m/min) up to 30 ft/min (9 m/min).



Model #	Description	Actual Length	Working Length	Total Weight
8518560	Advanced Digital 100 Series Removable Handle, 60' (18 m) Galvanized Cable Assy	70 ft (21.3 m)	60 ft (18 m)	30.5 lbs (13.8 kg)
8518558	Advanced Digital 100 Series Removable Handle, 60' (18 m) S.S. Cable Assy	70 ft (21.3 m)	60 ft (18 m)	30.5 lbs (13.8 kg)
8518564	Advanced Digital 100 Series Removable Handle, 60' (18 m) Technora Rope Assy	70 ft (21.3 m)	60 ft (18 m)	30.5 lbs (13.8 kg)
8518561	Advanced Digital 100 Series Removable Handle, 90' (27 m) Galvanized Cable Assy	100 ft (30 m)	90 ft (27 m)	32.5 lbs (14.7 kg)
8518559	Advanced Digital 100 Series Removable Handle, 90' (27 m) S.S. Cable Assy	100 ft (30 m)	90 ft (27 m)	32.5 lbs (14.7 kg)

ADVANCED DIGITAL 100 SERIES 2 SPEED WINCH W/ 9:1 POWER DRIVE & 4:1 REMOVABLE HANDLE

The Advanced Power Drive Digital Winch features a power drive hub on the 9:1 drive. An overload protection clutch installs between this power drive hub and an electric or pneumatic drill to eliminate overloading the winch during retrieval. This clutch also protects the winch operator and the retrieved worker from injury. The clutch is installed and removed without the use of tools when switching to the 4:1 manual crank option in emergencies. (8512936: Overload Protection Clutch sold separately.)



Model #	Description	Actual Length	Working Length	Total Weight
8518567	Advanced Digital 100 Series Power Drive, 60' (18 m) Galvanized Cable Assy	70 ft (21.3 m)	60 ft (18 m)	30.5 lbs (13.8 kg)
8518565	Advanced Digital 100 Series Power Drive, 60' (18 m) S.S. Cable Assy	70 ft (21.3 m)	60 ft (18 m)	30.5 lbs (13.8 kg)
8518568	Advanced Digital 100 Series Power Drive, 90' (27 m) Galvanized Cable Assy	100 ft (30 m)	90 ft (27 m)	32.5 lbs (14.7 kg)
8518566	Advanced Digital 100 Series Power Drive, 90' (27 m) S.S. Cable Assy	100 ft (30 m)	90 ft (27 m)	32.5 lbs (14.7 kg)
8518571	Advanced Digital 100 Series Power Drive, 60' (18 m) Technora Rope Assy	70 ft (21.3 m)	60 ft (18 m)	27 lbs (12.2 kg)

ADVANCED DIGITAL 200 SERIES 2 SPEED WINCH W/ REMOVABLE HANDLE

This Advanced Digital 200 Series Winch includes a removable aluminum crank handle to utilize both our 9:1 and 4:1 drives. These two drives offer the capability of retrieval/descent at average speeds from 13 ft/min (4 m/min) up to 30 ft/min (9 m/min).



Model #	Description	Actual Length	Working Length	Total Weight
8518581	Advanced Digital 200 Series Removable Handle, 140' (42 m) Galvanized Cable Assy	150 ft (45.7 m)	140 ft (42 m)	40 lbs (18.4 kg)
8518579	Advanced Digital 200 Series Removable Handle, 140' (42 m) S.S. Cable Assy	150 ft (45.7 m)	140 ft (42 m)	40 lbs (18.4 kg)
8518582	Advanced Digital 200 Series Removable Handle, 190' (58 m) Galvanized Cable Assy	200 ft (61 m)	190 ft (58 m)	43 lbs (13.8 kg)
8518580	Advanced Digital 200 Series Removable Handle, 190' (58 m) S.S. Cable Assy	200 ft (61 m)	190 ft (58 m)	43 lbs (13.8 kg)

ADVANCED DIGITAL 200 SERIES 2 SPEED WINCH W/ 9:1 POWER DRIVE & 4:1 REMOVABLE HANDLE

The Advanced Power Drive Digital Winch features a power drive hub on the 9:1 drive. An overload protection clutch installs between this power drive hub and an electric or pneumatic drill to eliminate overloading the winch during retrieval. This clutch also protects the winch operator and the retrieved worker from injury. The clutch is installed and removed without the use of tools when switching to the 4:1 manual crank option in emergencies. (8512936: Overload Protection Clutch sold separately.)



Model #	Description	Actual Length	Working Length	Total Weight
8518588	Advanced Digital 200 Series Power Drive, 140' (42 m) Galvanized Cable Assy	150 ft (45.7 m)	140 ft (42 m)	40 lbs (18.4 kg)
8518586	Advanced Digital 200 Series Power Drive, 140' (42 m) S.S. Cable Assy	150 ft (45.7 m)	140 ft (42 m)	40 lbs (18.4 kg)
8518589	Advanced Digital 200 Series Power Drive, 190' (58 m) Galvanized Cable Assy	200 ft (61 m)	190 ft (58 m)	43 lbs (13.8 kg)
8518587	Advanced Digital 200 Series Power Drive, 190' (58 m) S.S. Cable Assy	200 ft (61 m)	190 ft (58 m)	43 lbs (13.8 kg)

ADVANCED DIGITAL 300 SERIES 2 SPEED WINCH W/ REMOVABLE HANDLE

This Advanced Digital 300 Series Winch includes a removable aluminum crank handle to utilize both our 9:1 and 4:1 drives. These two drives offer the capability of retrieval/descent at average speeds from 13 ft/min (4 m/min) up to 30 ft/min (9 m/min).



Model #	Description	Actual Length	Working Length	Total Weight
8518603	Advanced Digital 300 Series Removable Handle, 240' (73 m) Galvanized Cable Assy	250 ft (76.2 m)	240 ft (73 m)	50 lbs (22.6 kg)
8518601	Advanced Digital 300 Series Removable Handle, 240' (73 m) S.S. Cable Assy	250 ft (76.2 m)	240 ft (73 m)	50 lbs (22.6 kg)
8518604	Advanced Digital 300 Series Removable Handle, 290' (88 m) Galvanized Cable Assy	300 ft (91 m)	290 ft (88 m)	53.5 lbs (19.5 kg)
8518602	Advanced Digital 300 Series Removable Handle, 290' (88 m) S.S. Cable Assy	300 ft (91 m)	290 ft (88 m)	53.5 lbs (19.5 kg)

ADVANCED DIGITAL 300 SERIES 2 SPEED WINCH W/ 9:1 POWER DRIVE & 4:1 REMOVABLE HANDLE

The Advanced Power Drive Digital 300 Winch features a power drive hub on the 9:1 drive. An overload protection clutch installs between this power drive hub and an electric or pneumatic drill to eliminate overloading the winch during retrieval. This clutch also protects the winch operator and the retrieved worker from injury. The clutch is installed and removed without the use of tools when switching to the 4:1 manual crank option in emergencies. (8512936: Overload Protection Clutch sold separately.)



Model #	Description	Actual Length	Working Length	Total Weight
8518610	Advanced Digital 300 Series Power Drive, 240' (73 m) Galvanized Cable Assy	250 ft (76.2 m)	240 ft (73 m)	50 lbs (22.6 kg)
8518608	Advanced Digital 300 Series Power Drive, 240' (73 m) S.S. Cable Assy	250 ft (76.2 m)	240 ft (73 m)	50 lbs (22.6 kg)
8518611	Advanced Digital 300 Series Power Drive, 290' (88 m) Galvanized Cable Assy	300 ft (91 m)	290 ft (88 m)	53.5 lbs (19.5 kg)
8518609	Advanced Digital 300 Series Power Drive, 290' (88 m) S.S. Cable Assy	300 ft (91 m)	290 ft (88 m)	53.5 lbs (19.5 kg)

ADVANCED BASIC WINCH & ACCESSORIES

The Advanced Basic Series Winch holds up to 50 ft (15 m) of 3/16" (5 mm) diameter cable/rope. The zinc-plated Basic Series Winch comes with a Load Limiter Clutch to indicate a fall or misuse (requires annual re-certification from Capital Safety). *NOTE: Please remember to order Pt# 8516824 Mounting Bracket when ordering the Basic Series Winches for use with our Advanced Hoists, Davits, Bases & Accessories.*



Model #	Description	Total Weight
8518669	Advanced Zinc Plated Basic Winch, Bolt-on Plate, 40' (12.2 m) Galvanized Cable Assembly	22 lbs (10 kg)
8518670	Advanced Zinc Plated Basic Winch, Bolt-on Plate, 40' (12.2 m) Stainless Steel Cable Assembly	22 lbs (10 kg)
8518671	Advanced Zinc Plated Basic Winch, Bolt-on Plate, 40' (12.2 m) Technora Rope Assembly	20 lbs (9 kg)
8517411	Padded Carrying bag for Basic or Digital Winch, comes with Carrying Handle	1.5 lbs (.7 kg)

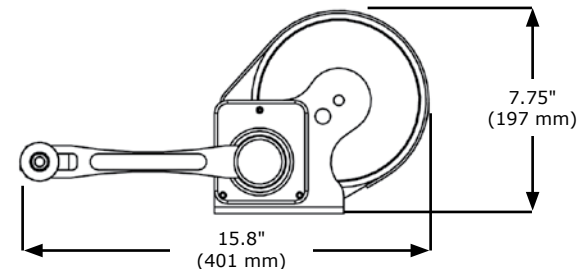
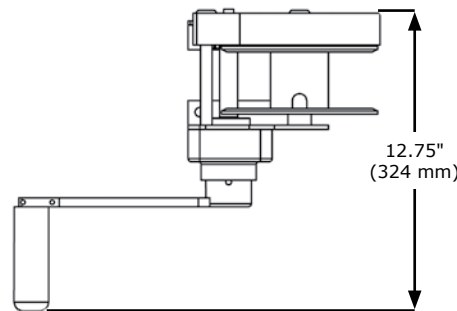

SALALIFT™ II WINCH PACKAGES

The Salalift™ II is manually operated for easy operation. Simply rotate the handle to raise or lower personnel or materials. Gear ratio is 6:1 with an average lifting speed of 12.75 ft/min (3.8 m/min). No power source is required. The Quick-Mount System incorporates a quick-mount bracket which mates with a bracket on all DBI-SALA support structures allowing the user to attach/detach device with a detent pin to make retrofitting easy (no additional hardware needed).



Model #	Description	Total Weight
8102001	Salalift™ II Winch w/ 60' (18 m) of 1/4" (6 mm) galvanized cable, mounting bracket & winch bag	36 lbs (16.3 kg)
8102003	Salalift™ II Winch w/ 60' (18 m) 1/4" (6 mm) stainless steel cable, mounting bracket & winch bag	36 lbs (16.3 kg)
8102009	Salalift™ II Winch w/ 90' (27 m) of 3/16" (5 mm) galvanized cable, mounting bracket & winch bag	35 lbs (15.8 kg)
8102011	Salalift™ II Winch w/ 90' (27 m) of 3/16" (5 mm) stainless steel cable, mounting bracket & winch bag	35 lbs (15.8 kg)
8102005	Salalift™ II Winch w/ 120' (37 m) of 3/16" (5 mm) galvanized cable, mounting bracket & winch bag	37 lbs (16.7 kg)
8102007	Salalift™ II Winch w/ 120' (37 m) of 3/16" (5 mm) stainless steel cable, mounting bracket & winch bag	37 lbs (16.7 kg)
8102050	Salalift™ II Winch w/ 50' (15 m) of synthetic Technora rope and lifeline counterweight, mounting bracket & winch bag	33 lbs (14.9 kg)

Winch Brackets & Accessories



WINCH/SRL ADAPTER WITH FLAT BACK
To attach DBI-SALA winch/SRL to structures.
8510207



QUICK RELEASE MOUNTING BRACKET
For Advanced Upper and Lower Masts.
8516824



MOUNTING BRACKET
Attaches to winch, mates with 8510207.
8516285



OVERLOAD PROTECTION CLUTCH
Features a maximum working load of 450 lbs (204 kg).
85129360



PADDED CARRYING BAG
For Basic or Digital winch, c/w Carrying Handle.
8517411

TRAINING & CONSULTING

Anytime, Anywhere... Our Site or Yours!

Capital Safety recognizes that our commitment to the life-and-death field of fall protection means that every product we produce must meet or exceed the toughest standards. But we also know that even the best equipment must be used correctly. This is why we have established our training division with the same care and attention that is critical in our manufacturing process.

Effective training means hands-on experience

The key to effective fall protection training is practical, hands-on experience. We offer a full range of fall protection and industrial rescue courses on-site or at one of our four state-of-the-art training centers located throughout the world.

Courses on-site apply professional training to your specific daily work activities. Courses at our institutes provide controlled environments uniquely designed to offer practical experience with scaffolding, fixed ladders, towers, sloped roofs, rebar and climbing walls, elevated catwalks, I-beams and confined spaces.

- *Training from top industry professionals*
- *Easy-to-understand training manuals*
- *Backed by decades of company experience*
- *Bilingual or all-Spanish instruction available*
- *State-of-the-art training facilities*
- *Confined Space training classes now available*

Confined Space Access & Egress Duration: 2 Days (16 hours)

Overview: While the primary focus of this course will be the rescue and retrieval of workers from within confined spaces, safe access and entry will also be discussed. This course is focused on the utilization of pre-engineered rescue systems and techniques that are easily adaptable to both team and peer rescue. It should be noted that this is not a technical rope rescue course. Theory presented is immediately reinforced through rescue exercises and scenarios.

This course will involve a high degree of hands on scenarios and will require workers to actively participate in rescue operations. Note, this course assumes that the workers have already been instructed in safe use of SCBA's if required, testing of the space, blanking, purging etc. Upon successful completion of this course, the student will receive a certificate acknowledging they have met or exceeded OSHA, ANSI and CSA requirements.

Topics Discussed:

- * Rescue theory, team development and scenario development
- * Fall arrest body holding devices and equipment applicable to confined space entry
- * Vertical and horizontal confined spaces
- * Rescuer safety; secondary backup systems
- * Simple rescues using pre-engineered, pre-rigged systems
- * Casualty packaging
- * Mock rescues and evaluations
- * Equipment selection, the rescuers with list

This course is intended for workers who will/or may be involved in the rescue of a co-worker from within a confined space. This course is designed to provide the basic skills necessary for both team development and establishment of peer rescue programs.



For more details on our training programs, customized site specific training, Confined Space Entry/ Retrieval and specialty courses, please contact us!



www.capitalsafety.com

You can also find us on Facebook and YouTube!



For Absolute Confidence At Height, DBI-SALA Offers A Full-Line Of Fall Protection And Rescue Gear



Full Body Harnesses

- Distributes forces throughout body during a fall
- Maximum comfort, freedom of movement and ease of use
- Exhaustive designs and configurations available to suit any need



Shock Absorbing Lanyards

- Limits fall arrest forces to under 900 lbs (408 kg)
- High strength construction
- Many configurations and hook styles available for any application



Anchorage Devices

- Superior 5,000 lb (2268 kg) strength
- Lightweight designs for ease of use
- Styles vary widely to attach to almost any structure



Self Retracting Lifelines

- Extends and retracts automatically for added comfort and safety
- Limits fall arrest forces to under 900 lbs (408 kg)
- Extends safe work area, available in lengths from 8' to 175' (2.4 m - 53 m)



Vertical Lifeline Systems

- Mobile and static designs
- Specialized designs available for both rope and cable
- Unique braking systems stop falls quickly and safely



Horizontal Lifeline Systems

- Precision engineered to provide horizontal movement and protection
- Wide range of styles available to suit any need
- Uniquely designed to enhance safety and productivity



Confined Space Rescue Systems

- Provide work support, fall protection and retrieval
- High quality, rugged systems ensure top performance when it counts
- Modular and lightweight designs for versatility and ease of use



Descent and Escape Systems

- Gets you down from high places in a hurry safely
- Lightweight and compact for fast and easy deployment
- Performance built for ultimate reliability and control



i-Safe™ Intelligent Safety System

- Save time and money with real-time information management
- Easily record and access inspections, inventory and user information
- RFID tag built-into most DBI-SALA brand fall protection equipment



FlexiGuard™ Custom Access Solutions

- Customized to fit your specific application
- Provides versatility and safety
- Highly engineered designs are rugged and durable



World-Class Training

- Training on-site or at 3 world-class training facilities
- Real hands-on experience
- Multiple training courses available



Industrial And Construction Net Systems

- Save lives and reduce lost time
- Economical compared to scaffolding, stay-in-place forms and planking
- Reusable and capable of being moved to alternative job sites

Contact Us Today

Capital Safety – USA

3833 SALA Way, Red Wing, MN 55066-5005

Phone: 651-388-8282 • Toll Free: 800-328-6146 • Fax: 651-388-5065

Web Site: www.capitalsafety.com • Email: information@capitalsafety.com

Latin America: +1 651 385 4301 • Canada: 800 387 7484 • Asia: +65 6558 7758 • Australia: 1800 245 002

Germany: +49 2634 8052 • New Zealand: 0800 212 505

Europe, Middle East, Africa: +33 (0)4 97 10 00 10 • Northern Europe: +44 (0) 1928 571324

capital
SAFETY