



Ratchet lever hoist model Yalehandy

Capacity 250 - 500 kg

This hoist is the smallest, lightest Yale ratchet lever hoist for professional applications.

Due to the multitude of application possibilities e.g. in industry, trade and service this new ratchet lever hoist is indispensable.

The extreme low tare weight and the very compact design make the hoist easy to use even in confined working conditions.

Features

- The drop forged suspension and load hooks, that yield under overload instead of breaking, are made from non-aging, high tensile alloy steel.
- The hooks are fitted with robust safety latches and are free to rotate 360°.
- The short and ergonomic handlever makes the hoist easy to operate.
- The enclosed design protects the internal parts from contamination.
- All parts of the disc type load brake are manufactured from high quality materials and are corrosion protected.

All ratchet lever hoists can be used for load attachment according to EN 12195.

Technical data model Yalehandy

Model	EAN-No. 4025092*	Capacity kg	Number of chain falls	Chain dimensions d x p mm	Lift with one full lever turn mm	Handle pull at WLL daN	Net weight at standard lift (3 m) kg
Yalehandy 250	*075039	250	1	4 x 12	80	25	2.2
Yalehandy 500	*077675	500	1	4 x 12	40	25	2.8

Dimensions model Yalehandy

Model	Yalehandy 250	Yalehandy 500
Amin., mm	240	282
B, mm	20	17
C, mm	21	24
D, mm	14	12
E, mm	160	160
F, mm	72	104
G, mm	33	38
H, mm	39	66
J, mm	98	116
K, mm	21	36
L, mm	77	80

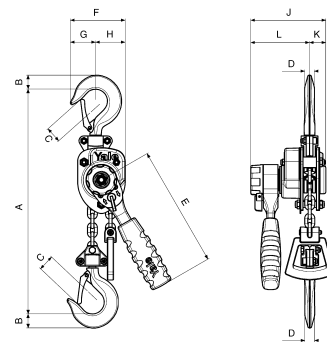

Model Yalehandy, 250 - 500 kg