

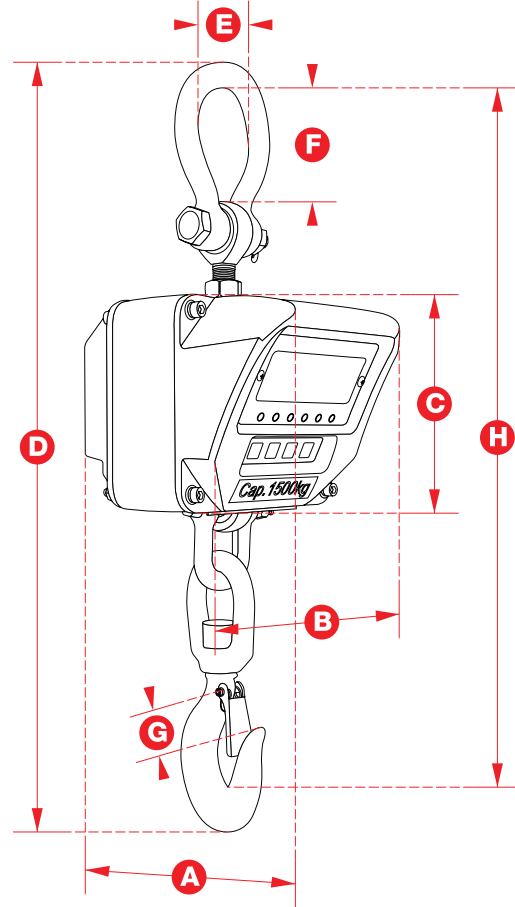

Heavy duty crane scale OIML approved.  
 Available in capacities 1.5, 3 and 5 tonne.  
 Bright LED display makes it easy to read in the lowest light applications.  
 Supplied with remote control for tare function.

DIMENSIONS (SEE TABLE BELOW)



Part Number	JWT1T5	JWT3T	JWT5T
Capacity	1.5t	3t	5t
Resolution	0.5kg	1kg	2kg
Units	kg	kg	kg
Weight	12kg	12kg	12kg
Safety Factor	5:1		
Battery Type	Internal rechargeable		
Battery Life	120hrs		
Display Type	24.6mm LED		
Operating Temp	0-40c		
Accuracy	±0.3% of applied load		
Dimension A	230	230	230
Dimension B	210	210	210
Dimension C	180	180	180
Dimension D	630	670	845
Dimension E	85	85	85
Dimension F	95	95	125
Dimension G	35	35	40
Dimension H	570	620	765

PRICES AND SPECS [mm]

JUMBOWEIGHER TRADE

