

Unit 1, Greensfield Industrial Estate
Willowburn Avenue
ALNWICK
NE66 2DG
Email: info@tigerlifting.co.uk
Tel: 01665 605130
Fax: 01665 603185

Tiger Lifting UK Ltd

www.tigerlifting.co.uk



Home of the Tiger hoisting range & Tiger subsea lifting products

Tiger Combination Chain Block & Trolley



Main Features

- Range from 500kg – 5000kg
- Ideal for locations where headroom is limited
- Geared and plain trolley versions available
- Twin bar or single bar trolley options
- Extended beam width available

Page 1 of 5
7 February 2012

Registered Office: Bulman House, Regent Centre, Gosforth, Newcastle upon Tyne NE3 3LS
Company Reg. No. 7744968 VAT Reg. No. 119 8240 10



Data Table

Single Bar Trolley & Chain Block Combinations

Product Code	Capacity (tonne)	Dimensions (mm)					Mass Kg @ std HOL		D - Extended width (mm)	
		A	B		C	H	D (track width)	Plain 3m HOL		Geared (3m HOL)
			Plain	Geared						
CCBTPS-0050 CCBTGS-0050	0.5	195	106	165	106	310	62-128	16.2	20.2	62-203
CCBTPS-0100 CCBTGS-0100	1.0	213	113	170	113	350	62-128	19.8	23.7	62-203
CCBTPS-0200 CCBTGS-0200	2.0	236	136	182	136	450	88-154	33.2	37.7	88-230
CCBTPS-0300 CCBTGS-0300	3.0	277	146	187	146	530	87-153	52.1	56.4	87-230

Technical Drawings

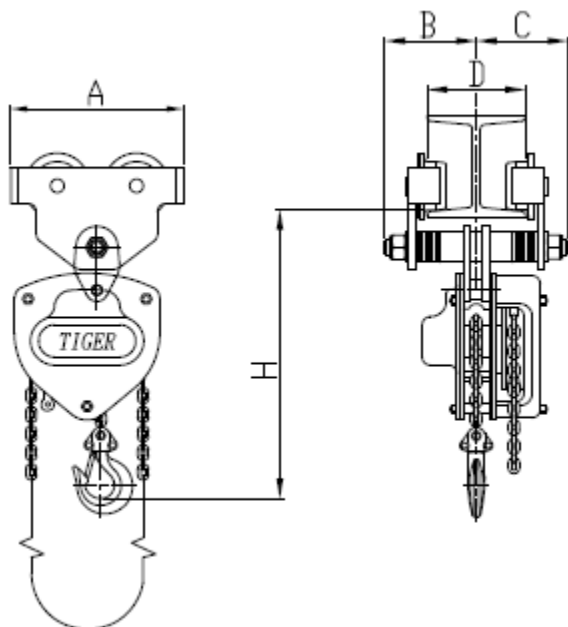

0.5t – 2.0t & 3.0t single bar plain trolley

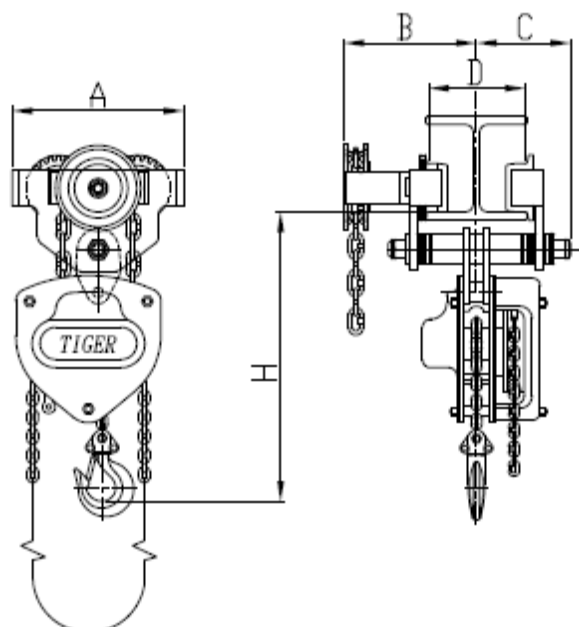

0.5t – 2.0t & 3.0t single bar geared trolley



Data Table

Twin Bar Trolley & Chain Block Combinations

Product Code	Capacity (tonne)	Dimensions (mm)						Mass Kg @ std HOL		D - Extended width (mm)
		A	B		C	H	D (track width)	Plain 3m HOL	Geared (3m HOL)	
			Plain	Geared						
CCBTPT-0050 CCBTGT-0050	0.5	179	109	168	109	316	62-128	17.1	21.1	62-203
CCBTPT-0100 CCBTGT-0100	1.0	195	111	178	111	342	62-128	20.4	24.4	62-203
CCBTPT-0200 CCBTGT-0200	2.0	235	134	184	134	446	88-154	33.9	38.4	88-230
CCBTPT-030T CCBTGT-030T	3.0	263	145	184	145	435	87-153	53.8	58.3	87-230
CCBTPT-0500 CCBTGT-0500	5.0	307	169	206	169	545	106-194	69.0	74.6	106-305

Technical Drawings

Twin Bar Plain Trolley Combinations

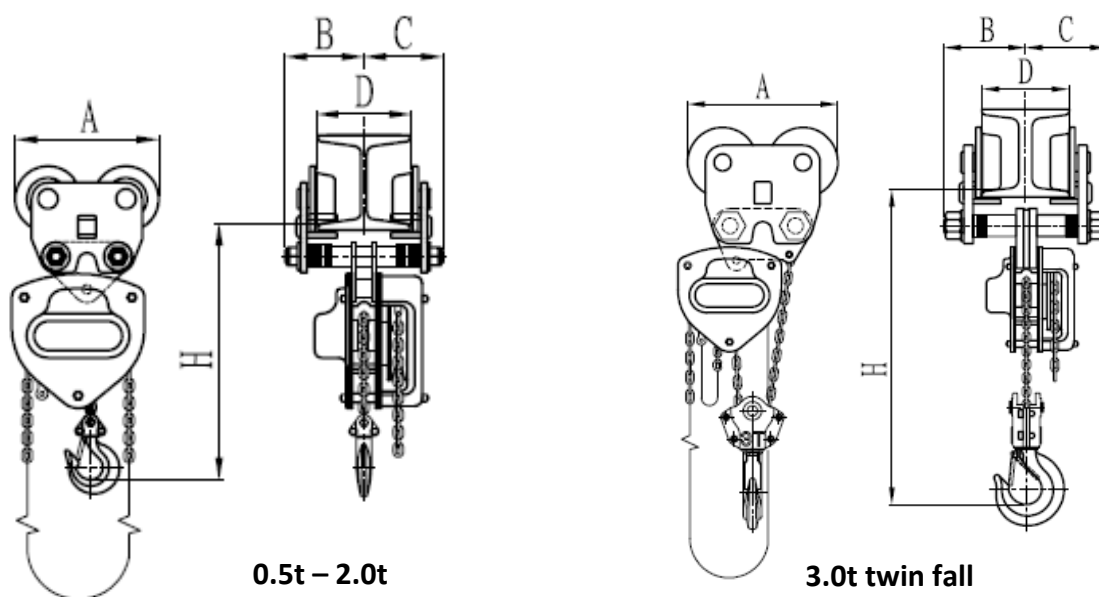

Unit 1, Greensfield Industrial Estate
Willowburn Avenue
ALNWICK
NE66 2DG
Email: info@tigerlifting.co.uk
Tel: 01665 605130
Fax: 01665 603185

Tiger Lifting UK Ltd



www.tigerlifting.co.uk

Home of the Tiger hoisting range & Tiger subsea lifting products

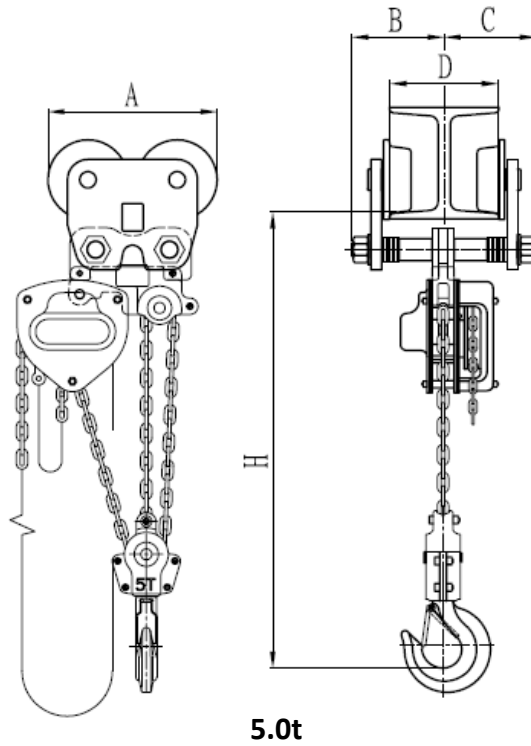

Unit 1, Greensfield Industrial Estate
Willowburn Avenue
ALNWICK
NE66 2DG
Email: info@tigerlifting.co.uk
Tel: 01665 605130
Fax: 01665 603185

Tiger Lifting UK Ltd



www.tigerlifting.co.uk

Home of the Tiger hoisting range & Tiger subsea lifting products

Twin Bar Geared Trolley Combinations

