



**innovative
safety**



Lashing chain systems
and accessories in G10 quality
(for load securing in accordance with EN 12195-3)

■ Pewag Chain Lashing Systems for the Road Transport Industry

Load lashing or load restraint is a vital component for the safe transport of goods whether this be by road, rail or sea. Outside forces applied to the load caused by the effects of breaking, accelerating or cornering have a dramatic effect on how the load is to be restrained.

In a similar way to how we select lifting equipment, the shape and type of load as well as the effects of the working angles of the lashings, can increase the forces considered and consequently these factors affect the choice of both the type of lashing that should be selected and the method of how they should be used (friction or direct lashing).

BS EN 12195 Parts 1 to 4 were introduced to provide a means of conforming to the essential safety requirements for lashing and load restraint in the Common European market and thus enabling the free movement of goods.

Lashing equipment supplied by Brindley Chains is of high quality and produced by Pewag in Austria.

At Brindley Chains we are able to offer lashing chains and components in various grades, from our standard Grade 10 system which offers the user a 25% increase in lashing capacity for the same size chain over G8 (as the minimum requirement under the standard), to the new Grade 12 profiled chain system which was launched in Europe in May 2008.

Whatever Pewag chain system you choose, it will meet or exceed the British and European standards.

This brochure contains all the information necessary to select the correct type and grade of equipment to suit your specific requirements. Whether you require direct or friction lashings, this guide will assist you in making an informed decision for selecting and specifying all manner of chain lashing equipment. With the aid of pre-calculated selection charts you will be able to choose the correct chain size and number of lashings to safely restrain the load.

Further details of chains, components, lashing points and other ancillary equipment can also be found within the brochure as well as details of certification and maintenance criteria and other services offered by us to the transport industry.

Table of contents

Lashing chain systems in G10 quality	3-4
Round steel chains and accessories in G10 quality	5-6
Lifting & lashing points	7-8
pewag Lashmate & G10 lashing tables	9-10
Lashing chain systems – important information	11
Explanation of the pewag lashing table	12
Friction factors	13
Information for use	14-17

Lashing chain systems in G10 quality

In accordance with EN 12195-3

■ ZRSW Lashing chain G10

- For load securing with 25% higher lashing capacity (LC) than conventional G8 lashing chains
- Kit system
- In accordance with EN 12195-3
- Standard length 3.5 metres
- Customised lengths available on request
- Supplied with ID-tag in accordance with EN 12195-3 with G10 values

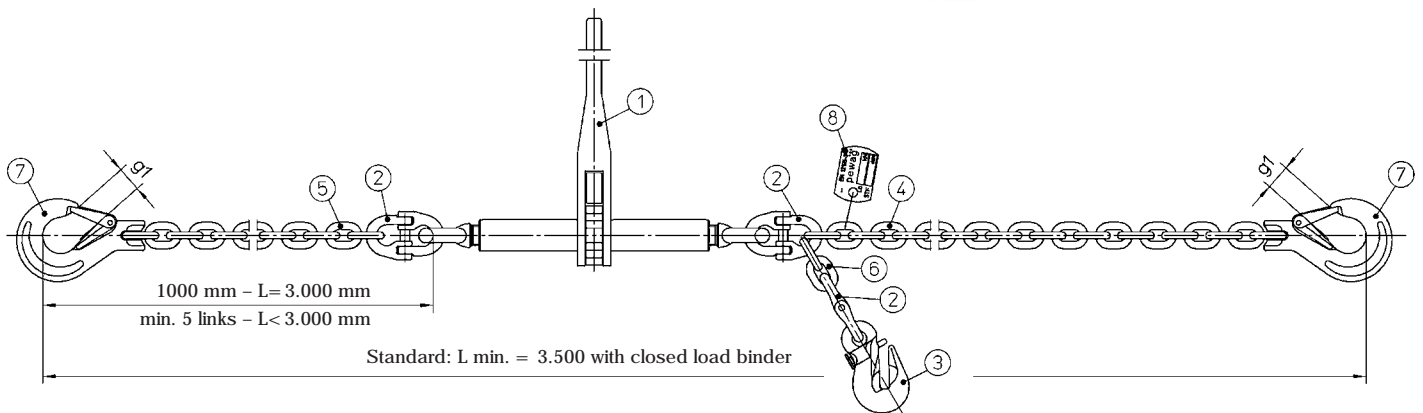

- 1 Load binder RSW
- 2 Connex connecting link CW
- 3 Grab hook with safety catch PSW
- 4-6 Chain WIN 200
- 7 Clevis sling hook KHSW
- 8 Identification tag

Type	LC Lashing capacity [kN]	Length RLSS closed position [mm]	Length RLSS open position [mm]	Tensioning Length [mm]	STF – standard tension force [daN]	Opening g1 [mm]	Weight kg/pc. approx.
ZRSW 7 EN G10 3.5	38	346	501	155	1900	26	8,4
ZRSW 8 EN G10 3.5	50	346	501	155	1900	26	9,7
ZRSW 10 EN G10 3.5	80	358	513	155	3000	31	14,5
ZRSW 13 EN G10 3.5	134	571	868	297	2500	39	26,1
ZKSW 16 EN G10 3.5*	200	530	780	250	4000	45	37,7

* Size 16 only with clevis turnbuckle KSSW 16 available

Please find further information regarding selection and capacities on page 12.

Lashing chain systems in G10 quality

In accordance with EN 12195-3

ZKW Lashing chain G10 as two part system

- For use with separate loadbinder in G10 quality – (*Supplied seperately)
Advantage: the load binder can be attached to the chain in any position
- For load securing with 25% higher lashing capacity (LC) than conventional G8 lashing chains
- Kit system
- In accordance with EN 12195-3
- Standard length 3.5 metres
- Customised lengths available on request
- Supplied with ID-tag in accordance with EN 12195-3 with G10 values

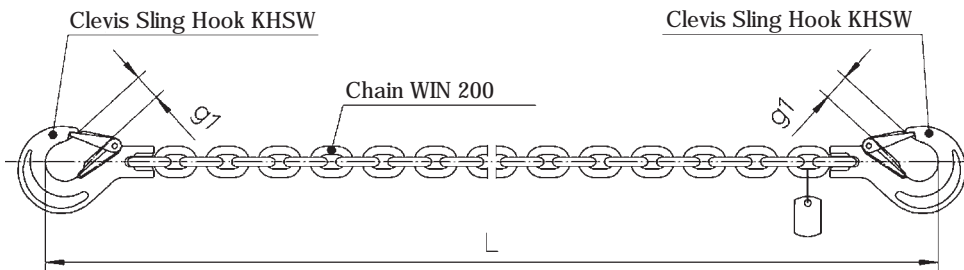

Type	LC Lashing capacity [kN]	L [mm]	g1 [mm]	Weight kg/pc. approx.
ZKW 7 EN G10 3.5	38	3.500	26	5,17
ZKW 8 EN G10 3.5	50	3.500	26	6,4
ZKW 10 EN G10 3.5	80	3.500	31	10,27
ZKW 13 EN G10 3.5	134	3.500	39	17,49

*Ratchet loadbinder complete with grab hooks (ZKW EN G10) supplied seperately. (See page 5 for details).

Basic application principle of a two part Lashing chain system in G10

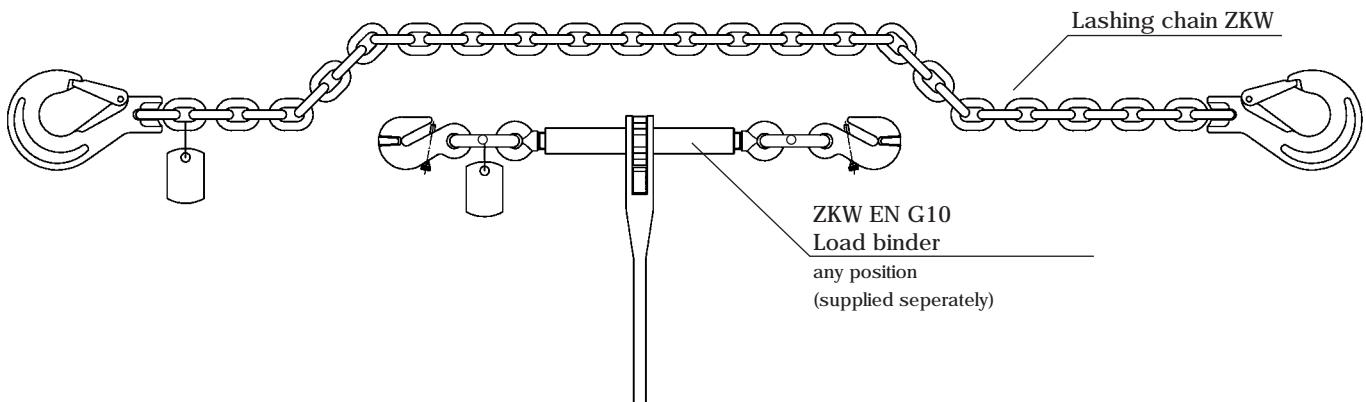

Please find further information regarding selection and capacities on page 12.

Round steel chains and accessories in G10 quality

- 25% higher lashing capacity (LC) than conventional G8 Lashing Chains.
- An easy and fast assembly of the lashing chains with the help of clevis parts or connex connecting links by a competent person is possible.

Chain Winner 200

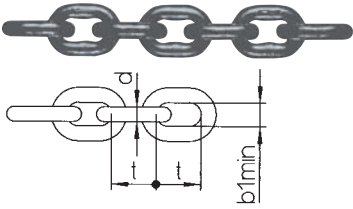

Code	Nominal diameter d	Standard delivery length [m]	Pitch t	Inside Width b1 min.	Outside Width b2 max.	Lashing capacity [kN]	Breaking force [kN]	Weight kg/m
WIN 7 200	7	300/50	21	9,5	25,2	38	77	1,2
WIN 8 200	8	250/50	24	10,9	28,8	50	100	1,57
WIN 10 200	10	150/50	30	13,5	36,0	80	157	2,46
WIN 13 200	13	80/50	39	17,5	46,8	134	266	4,18
WIN 16 200	16	50/25	48	21,5	57,6	200	402	6,28

Winner 200 – meets the requirements of ASTM A973/A973M-01 and of EN 818-2 but with higher load capacity (however admissible operating temperature of 200°C max.) and 98/37/EC & 2006/42/EC Machinery Directive

Please find more detailed information about Winner 200 chains in our lifting catalogue.

Load binder RLLS for lashing chains

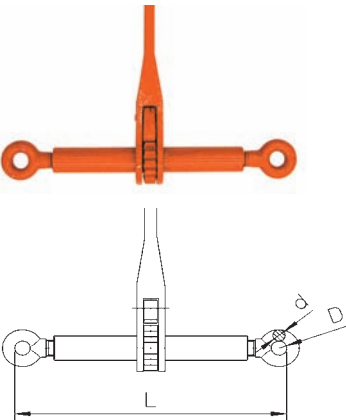

Type	LC Lashing capacity [kN]	STF – Standard tension force [daN]	Length RLSS closed [mm]	Length RLSS open [mm]	Tensioning Length [mm]	D [mm]	d [mm]	Weight kg/pc.
RLLS 7-8 Type A	50	1900	346	501	155	20	16	3.2
RLLS 10 Type B	80	3000	358	513	155	26.5	18	3.8
RLLS 13 Type C*	134	2500	571	868	297	31	22	9.9

* Loadbinder also usable for a 16 mm G8 chain. Please consider that for this application the correct lashing capacity LC = 160 kN.

Load binder ZKW for lashing chains

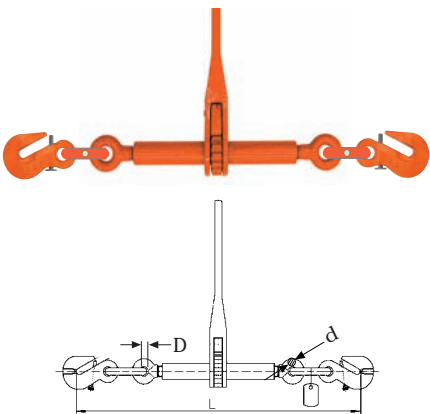

Type	LC Lashing capacity [kN]	STF – Standard tension force [daN]	Length ZKW closed [mm]	Length ZKW open [mm]	Tensioning Length [mm]	D [mm]	d [mm]	Weight kg/pc.
ZKW7ENG10	38	1900	589	744	155	20	16	4.24
ZKW8ENG10	50	1900	670	765	155	20	16	4.36
ZKW10ENG10	80	3000	678	833	155	26.5	18	6.26
ZKW13ENG10*	134	2500	973	1270	297	31	22	14.9

* Loadbinder also usable for a 16 mm G8 chain. Please consider that for this application the correct lashing capacity LC = 160 kN.

Clevis turnbuckle KSSW for lashing chains

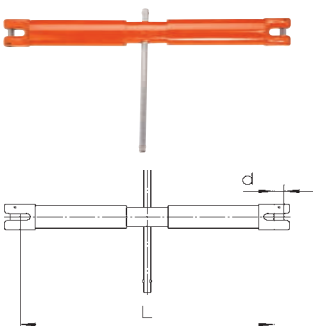

Type	LC Lashing capacity [kN]	STF – Standard tension force [daN]	Length KSSW closed [mm]	Length KSSW open [mm]	Tensioning Length [mm]	d [mm]	Weight kg/pc.
KSSW 16	200	4.000	530	780	250	20	10

Please find further information regarding selection and capacities on page 12.

CW connex connecting link

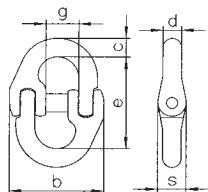

Load pin and bush CBH are also available separately.
 Connecting link for:
 Load binder – chain
 Master link – chain
 Chain – chain
 Hook – chain

Type	LC Lashing capacity [kN]	e mm	c mm	s mm	d mm	b mm	g mm	Weight kg/pc.
CW 7	38	51	10	12,9	9	46,5	16,3	0,12
CW 8	50	61,5	11,5	15	10	53	18,35	0,18
CW 10	80	72	12,6	17,8	12,6	63	23	0,33
CW 13	134	88	19	22	16,7	79	27,6	0,7
CW 16	200	103	21	29	21	106	33	1,14

Assembly:

KHSW clevis sling hook

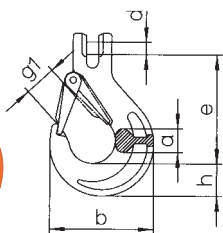

Type	LC Lashing capacity [kN]	e mm	h mm	a mm	d mm	g1 mm	b mm	Weight kg/pc.
KHSW 7	38	95	28	19	9	26	90	0,6
KHSW 8	50	94,5	28	19	10	26	90	0,6
KHSW 10	80	109	34,5	25	12,5	31	108	1,1
KHSW 13	134	136	41	34	16	39	131	2
KHSW 16	200	155	49	37	20	45	153	3,48

General purpose hook, can be used without transition link and without connecting link.
 With forged safety catch. Replacement load pin / retaining pin & safety catch set also available as spare parts.

HSW eye sling hook

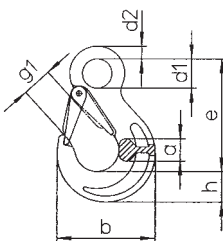

Type	LC Lashing capacity [kN]	e mm	h mm	a mm	d1 mm	d2 mm	g1 mm	b mm	Weight kg/pc.
HSW 7-8	50	106	27	19	25	11	26	88	0,5
HSW 10	80	131	33	26	34	16	31	108,5	1,1
HSW 13	134	164	43,5	33	43	19	39	133,7	2
HSW 16	200	182,5	50	40	50	24,5	45	154,6	3,5

To be connected to the chain with connex connecting link CW. All hooks with forged safety catch.
 Safety catch set also available as spare part.

PSW grab hook with safety catch

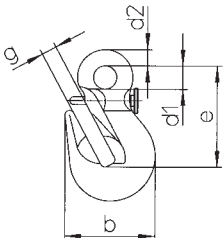

Type	LC Lashing capacity [kN]	e mm	b mm	d1 mm	d2 mm	g mm	Weight kg/pc.
PSW 7-8	50	70,5	58	20	11,5	10,5	0,4
PSW 10	80	88	76	22	15	13	0,9
PSW 13	134	113	101	26	18	17	1,8
PSW 16	200	129	118	32	23	19	3,6

Shortening hook, protects against accidental release of the chain.
 Safety catch set also available as spare part.

AW master link

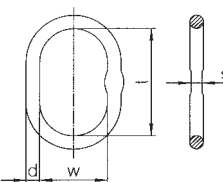

Type	for chain-ø	LC Lashing capacity [kN]	d mm	t mm	w mm	s mm	Weight kg/pc.
AW 13	7	46	13	110	60	10	0,34
AW 16	8	70	16	110	60	14	0,53
AW 18	10	100	18	135	75	14	0,86
AW 22	13	152	23	160	90	17	1,6
AW 26	16	200	27	180	100	20	2,46

Lifting & lashing points

■ PLAW profilift alpha

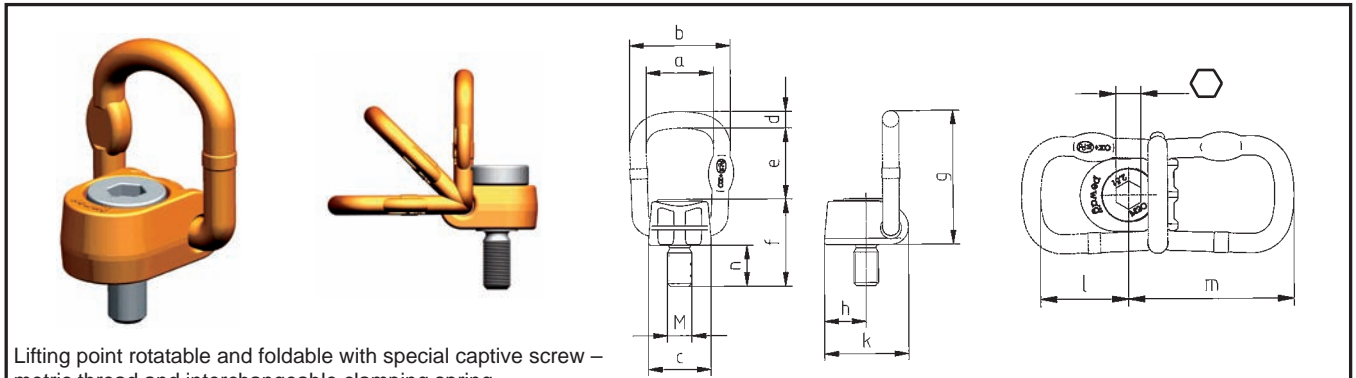

Lifting point rotatable and foldable with special captive screw – metric thread and interchangeable clamping spring.

Code	Load capacity kg	Thread	Fastening torque [Nm]	a	b	c	d	e	f	g	h	k	l	m	n	⬡	Weight kg/pc.
PLAW 0.3*	300	M 8	35	45	67	40	11	44	70	91	23	55	47	85	33	6	0.48
PLAW 0.63	630	M 10	70	45	67	40	11	44	70	91	23	55	47	85	33	17	0.53
PLAW 1	1000	M 12	120	45	67	40	11	44	70	91	23	55	47	85	33	10	0.58
PLAW 1.5	1500	M 16	200	45	67	40	11	44	70	91	23	55	47	85	33	17	0.60
PLAW 2.5	2500	M 20	300	54	81	50	13	57	70	107	33	67	60	113	33	17	1.00
PLAW 4	4000	M 24	400	75	115	67	20	70	87	138	45	100	67	130	37	19	2.81
PLAW 6	6000	M 30	500	75	115	67	20	70	99	138	45	100	67	130	50	22	2.96
PLAW 7*	7000	M 26	800	75	115	67	20	70	105	138	45	100	67	130	56	27	3.05
PLAW 8	8000	M 36	800	93	147	85	27	90	117	180	52	120	85	174	54	27	5.91
PLAW 10	10000	M 42	1500	93	147	85	27	90	126	180	52	120	85	174	63	32	6.16
PLAW 15*	15000	M 42	1500	115	181	105	33	115	165	238	63	150	119	221	73	19	11.65
PLAW 20*	20000	M 48	2000	115	181	105	33	115	165	238	63	150	119	221	73	32	11.70

■ PLBW profilift beta

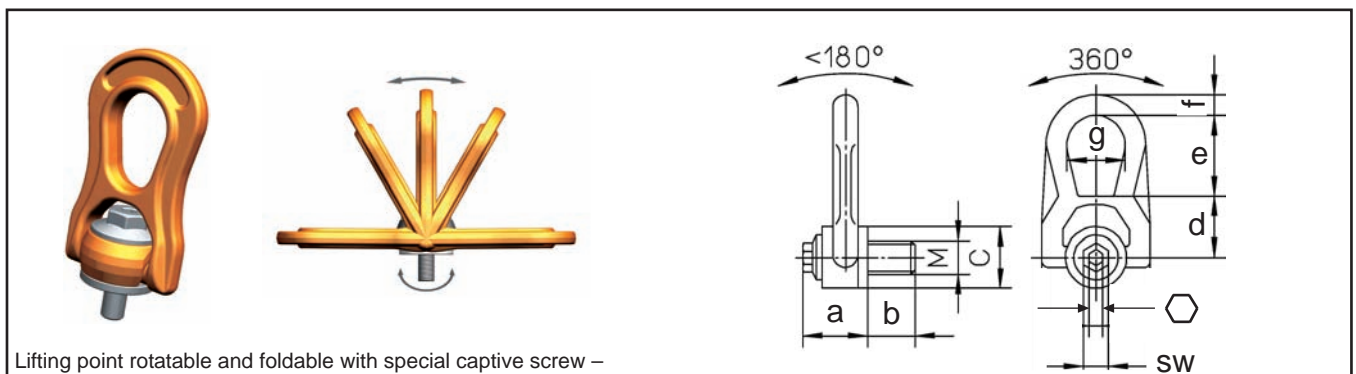

Lifting point rotatable and foldable with special captive screw – metric thread and interchangeable clamping spring.

Code	Load capacity kg	Thread	Fastening torque [Nm]	a	b	c	d	e	f	g	⬡	SW	Weight kg/pc.
PLBW 0.3	300	M 8	6	27.8	14.2	30	30.2	38	17.5	27	8	15	0.30
PLBW 0.6	600	M 10	10	27.8	16.2	30	30.2	38	17.5	27	8	15	0.31
PLBW 1	1000	M 12	15	27.8	18.2	30	30.2	38	17.5	27	8	15	0.32
PLBW 1.3	1300	M 14	30	43.2	22.3	45	45	55	25	38	10	24	1.03
PLBW 1.6	1600	M 16	50	43.2	24.3	45	45	55	25	38	10	24	1.04
PLBW 2	2000	M 18	70	43.2	27.3	45	45	55	25	38	10	24	1.07
PLBW 2.5	2500	M 20	100	43.2	30.3	45	45	55	25	38	10	24	1.08
PLBW 3	3000	M 22	120	64.1	33.4	67.5	67.8	85	37.5	58	14	36	3.52
PLBW 4	4000	M 24	160	64.1	36.4	67.5	67.8	85	37.5	58	14	36	3.55
PLBW 5	5000	M 27	200	64.1	40.4	67.5	67.8	85	37.5	58	14	36	3.60
PLBW 6.3	6300	M 30	250	64.1	45.4	67.5	67.8	85	37.5	58	14	36	3.68
PLBW 8	8000	M 33	270	106.3	53.7	108	108.8	132	60	91	19	55	14.32
PLBW 10	10000	M 36	320	106.3	58.7	108	108.8	132	60	91	19	55	14.43
PLBW 12.5	12500	M 42	400	106.3	68.7	108	108.8	132	60	91	19	55	14.72
PLBW 15	15000	M 48	600	106.3	73.7	108	108.8	132	60	91	19	55	15.03

* NOTE: When used for lashing, load capacities are doubled due to reduced safety factor of 2:1 for lashing against 4:1 for lifting!

LAT DSS Lifting and lashing points

LAT (DSS) lifting point

Can be swiveled by 360°, tilted by 180°, with metric thread.
Can be loaded with 100% load capacity along, at an angle and across the screw axis.

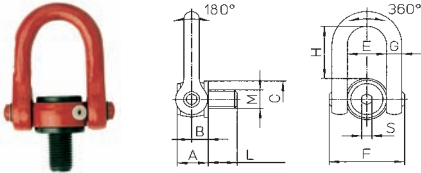

Code	Load capacity kg	A	B	C	D	E	F	G	H	L	S	M	Weight kg/pc.
LATDSSM56	25000	79	38	90	205	91	184	33	125	78	19	56x6	11,30
LATDSSM64	32100	79	38	95	205	91	184	33	125	90	19	64x6	12,20

Eyebolts

RGS alloy steel eyebolts

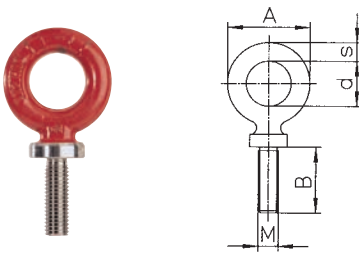

To be used as lifting points on machine parts.
Alloy steel eye bolts may only be tightened manually. Designed for vertical lifting.
Please check our manual.

Code	Load capacity kg	M	d	A	B	s	Weight kg/pc.
RGS 8	400	8	20	36	25	8	0,06
RGS 10	700	10	22	42	30	10	0,10
RGS 12	1000	12	27	51	36	12	0,20
RGS 14	1200	14	30	58	40	14	0,30
RGS 16	1500	16	36	66	53	16	0,40
RGS 20	2500	20	40	76	58	18	0,70
RGS 24	4000	24	54	98	82	22	1,32

Warning!

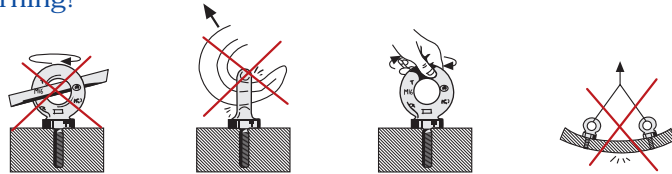

AOR High-tensile bolt-on lifting and lashing points

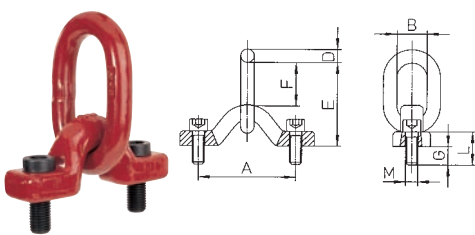

For bolting onto machine parts or truck bodies.
Ideal for lifting and lashing.

Code	Load capacity kg	Thread	Fastening torque [Nm]	for chain Ø	E	D	F	B	A	G	L	Weight kg/pc.
AOR 10	3150	M 16	170	10	112	18	57	40	90	25	45	0,78
AOR 16	8000	M 30	950	16	183	26	93	65	150	50	80	5,78
AOR 22	15000	M 36	1.900	22	226	36	114	75	175	54	90	11,13

LPW / PLE High-tensile weld-on lifting and lashing points

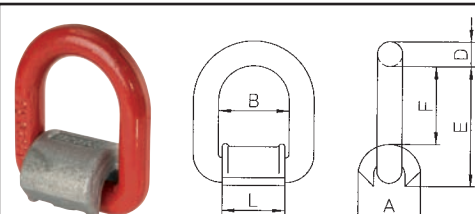

For welding onto machine parts or truck bodies.
Ideal for lifting and lashing.
Observe welding instructions provided!

Code	Load capacity kg	E	D	F	B	A	L	Weight kg/pc.
LPW 6 / PLE 6	1120	67	11	40	38	36	35	0,28
LPW 8 / PLE 8	2000	75	13	43	40	37	37	0,39
LPW 10 / PLE 10	3150	83	17	48	43	41	40	0,64
LPW 13 / PLE 13	5300	101	20	56	52	57	50	1,70
LPW 16 / PLE 16	8000	118	23	70	67	63	64	2,00
LPW 22 / PLE 22	15000	159	33	93	93	89	90	5,50

pewag G10 lashing table (Friction)

■ pewag Lashmate

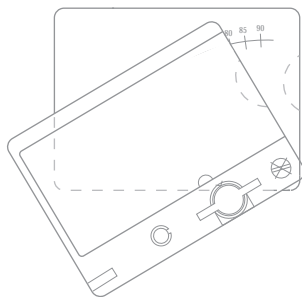

As a world leader in load securement Pewag have developed a simple and easy to use tool "LASHMATE" to aid the operator in determining lashing angles. This compact unit with its built in laser light allows the user to measure the lashing angle from the lashing point on the load to the attachment point on the vehicle. Saving time and labour needed to rig lashings to the load. With the help of the lashing tables (for both direct and friction lashings) and the operating instructions supplied with the kit, the correct size (capacity) and number of chain lashings can be safely determined.

LASHMATE is available now from your local Pewag distributor.

■ pewag G10 lashing table for the load restrained during road transport

The tables below show the maximum loading weights that can be secured during road transport using **one** lashing device type ZRSW and ZKW (a minimum of **two** devices must be used). The total number of lashings to be used will be determined by the total weight of the load to be secured.

Important information for friction lashing

Always use the table associated to your chosen pewag lashing device/chain. For correct choice, please check the marking on the pewag device.

Example of marking:

RLLS 7-8

Marking:
'pewag', 'Type A'



For correct measurement of angle and use of table, please consult user information.

Details of angles to be considered

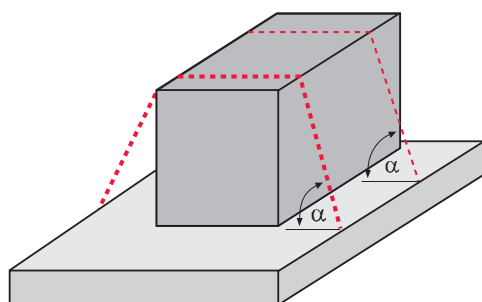

Load binder: RLLS 7-8 (marking: 'pewag', 'Type A')

Working angle	Max. load capacities [kg] using dynamic friction factors on a single loaded lashing chain						
	0,1	0,2	0,3	0,4	0,5	0,6	
Angle to the loading area	90	400	950	1710	2850	4750	8550
	85	400	940	1700	2830	4730	8510
	80	400	930	1680	2800	4670	8420
	70	380	890	1600	2670	4460	8030
	60	350	820	1480	2460	4110	7400
	50	310	720	1300	2180	3630	6540
	40	260	610	1090	1830	3050	5490
	30	200	470	850	1420	2370	4270

Load binder: RLLS 10 (marking: 'pewag', 'Type B')

Working angle	Max. load capacities [kg] using dynamic friction factors on a single loaded lashing chain						
	0,1	0,2	0,3	0,4	0,5	0,6	
Angle to the loading area	90	640	1500	2700	4500	7500	13500
	85	640	1490	2680	4480	7470	13440
	80	630	1470	2650	4430	7380	13290
	70	600	1400	2530	4220	7040	12680
	60	550	1290	2330	3890	6490	11690
	50	490	1140	2060	3440	5740	10340
	40	410	960	1730	2890	4820	8670
	30	320	750	1350	2250	3750	6750

Load binder: RLLS 13 (marking: 'pewag', 'Type C')

Working angle	Max. load capacities [kg] using dynamic friction factors on a single loaded lashing chain						
	0,1	0,2	0,3	0,4	0,5	0,6	
Angle to the loading area	90	530	1250	2250	3750	6250	11250
	85	530	1240	2240	3730	6220	11200
	80	520	1230	2210	3690	6150	11070
	70	500	1170	2110	3520	5870	10570
	60	460	1080	1940	3240	5410	9740
	50	410	950	1720	2870	4780	8610
	40	340	800	1440	2410	4010	7230
	30	260	620	1120	1870	3120	5620

Load binder: KSSW 16 (marking: '16-8W')

Working angle	Max. load capacities [kg] using dynamic friction factors on a single loaded lashing chain						
	0,1	0,2	0,3	0,4	0,5	0,6	
Angle to the loading area	90	850	2000	3600	6000	10000	18000
	85	850	1990	3580	5970	9960	17930
	80	840	1960	3540	5900	9840	17720
	70	800	1870	3380	5630	9390	16910
	60	740	1730	3110	5190	8660	15580
	50	650	1530	2750	4590	7660	13780
	40	550	1280	2310	3850	6420	11570
	30	420	1000	1800	3000	5000	8990

pewag G10 lashing table (Direct)

pewag G10 lashing table for the load restrained during road transport

These tables show the maximum loading weights that can be secured during road transport using **four** identical symmetrically adjusted lashing devices type ZRSW and ZKW

LC = 38kN (Winner 7 mm, grade 10) (marking: 'pewag', 'Type A')

Working angles		Max. load capacities [kg] using dynamic friction factors on 4 equally loaded lashing chains						
α	β	0,01	0,1	0,2	0,3	0,4	0,5	0,6
5 - 14	21 - 30				13,500	17,050	22,950	34,750
	31 - 40	7,150	8,300	9,850	11,950	15,150	20,400	30,950
	41 - 50	6,000	7,000	8,300	10,100	12,800	17,300	26,300
	51 - 60	4,650	5,500	6,500	7,950	10,100	13,700	
15 - 35	21 - 30				13,350	17,800	24,450	37,650
	31 - 40	6,050	7,400	9,400	12,150	16,000	22,000	34,000
	41 - 50	5,100	6,300	8,100	10,600	13,750	19,000	29,450
	51 - 60	3,950	5,050	6,600	8,500	11,100	15,500	24,250
36 - 50	21 - 30			8,950	11,950	16,350	23,800	38,600
	31 - 40	4,800	6,150	8,150	10,950	15,150	22,150	36,150
	41 - 50	4,000	5,300	7,150	9,750	13,650	20,150	33,150
	51 - 60		4,300	6,000	8,350	11,900	17,650	28,750

LC = 200kN (Winner 16 mm, grade 10) (marking: '16-8W')

Working angles		Max. load capacities [kg] using dynamic friction factors on 4 equally loaded lashing chains						
α	β	0,01	0,1	0,2	0,3	0,4	0,5	0,6
5 - 14	21 - 30				71,100	89,750	120,800	183,000
	31 - 40	37,750	43,850	52,000	63,100	79,750	107,550	163,050
	41 - 50	31,700	37,000	43,850	53,300	67,500	91,150	138,500
	51 - 60	24,650	28,950	34,350	41,900	53,250	72,200	
15 - 35	21 - 30				70,500	93,850	128,750	198,350
	31 - 40	32,050	39,100	49,450	63,950	84,300	115,900	179,000
	41 - 50	26,950	33,350	42,750	55,850	72,400	100,000	155,200
	51 - 60	21,000	26,650	34,950	44,800	58,600	81,600	127,650
36 - 50	21 - 30			47,300	62,900	86,300	125,250	203,250
	31 - 40	25,300	32,500	43,000	57,750	79,850	116,700	190,400
	41 - 50	21,300	27,950	37,750	51,400	71,950	106,150	174,500
	51 - 60		22,700	31,600	44,050	62,750	93,100	151,400

LC = 50kN (Winner 8 mm, grade 10) (marking: 'pewag', 'Type A')

Working angles		Max. load capacities [kg] using dynamic friction factors on 4 equally loaded lashing chains						
α	β	0,01	0,1	0,2	0,3	0,4	0,5	0,6
5 - 14	21 - 30				17,750	22,400	30,200	45,750
	31 - 40	9,400	10,950	13,000	15,750	19,900	26,850	40,750
	41 - 50	7,900	9,250	10,950	13,300	16,850	22,750	34,600
	51 - 60	6,150	7,200	8,550	10,450	13,300	18,050	
15 - 35	21 - 30				17,600	23,450	32,150	49,550
	31 - 40	8,000	9,750	12,350	15,950	21,050	28,950	44,750
	41 - 50	6,700	8,300	10,650	13,950	18,100	25,000	38,800
	51 - 60	5,250	6,650	8,700	11,200	14,650	20,400	31,900
36 - 50	21 - 30			11,800	15,700	21,550	31,300	50,800
	31 - 40	6,300	8,100	10,750	14,400	19,950	29,150	47,600
	41 - 50	5,300	6,950	9,400	12,850	17,950	26,500	43,600
	51 - 60		5,650	7,900	11,000	15,650	23,250	37,850

LC = 80kN (Winner 10 mm, grade 10) (marking: 'pewag', 'Type B')

Working angles		Max. load capacities [kg] using dynamic friction factors on 4 equally loaded lashing chains						
α	β	0,01	0,1	0,2	0,3	0,4	0,5	0,6
5 - 14	21 - 30				28,400	35,900	48,300	73,200
	31 - 40	15,100	17,500	20,800	25,250	31,900	43,000	65,200
	41 - 50	12,650	14,800	17,500	21,300	27,000	36,450	55,400
	51 - 60	9,850	11,550	13,700	16,750	21,300	28,850	
15 - 35	21 - 30				28,200	37,550	51,500	79,300
	31 - 40	12,800	15,650	19,750	25,550	33,700	46,350	71,600
	41 - 50	10,750	13,300	17,100	22,350	28,950	40,000	62,050
	51 - 60	8,400	10,650	13,950	17,900	23,450	32,650	51,050
36 - 50	21 - 30			18,900	25,150	34,500	50,100	81,300
	31 - 40	10,100	13,000	17,200	23,100	31,950	46,650	76,150
	41 - 50	8,500	11,150	15,100	20,550	28,750	42,450	69,800
	51 - 60		9,050	12,650	17,600	25,100	37,200	60,550

LC = 134kN (Winner 13 mm, grade 10) (marking: 'pewag', 'Type C')

Working angles		Max. load capacities [kg] using dynamic friction factors on 4 equally loaded lashing chains						
α	β	0,01	0,1	0,2	0,3	0,4	0,5	0,6
5 - 14	21 - 30				47,600	60,100	80,950	122,600
	31 - 40	25,250	29,350	34,850	42,300	53,450	72,050	109,250
	41 - 50	21,200	24,800	29,350	35,700	45,200	61,050	92,800
	51 - 60	16,500	19,400	23,000	28,050	35,700	48,350	
15 - 35	21 - 30				47,200	62,900	86,250	132,900
	31 - 40	21,450	26,200	33,150	42,850	56,500	77,650	119,950
	41 - 50	18,050	22,350	28,600	37,400	48,500	67,000	104,000
	51 - 60	14,050	17,850	23,400	30,000	39,250	54,700	85,500
36 - 50	21 - 30			31,700	42,150	57,800	83,900	136,150
	31 - 40	16,950	21,750	28,800	38,700	53,500	78,200	127,550
	41 - 50	14,250	18,750	25,250	34,450	48,200	71,100	116,900
	51 - 60		15,200	21,150	29,500	42,050	62,350	101,450

Details of angles to be considered

Angle α

side view

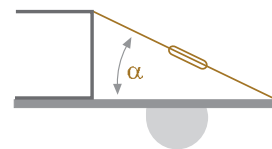

Angle β

plan view

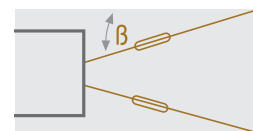

Important information for direct lashing

Always use the table associated to your chosen pewag lashing chain. For correct choice, please compare the LC quoted on your ID-tag with the LC figuring in the table.

Example of marking on the ID-tag:

LC 38kN

= lashing capacity of pewag Winner chain 7 mm, grade 10



For correct measurement of angle and use of table, please consult user information.

■ Marking and documentation

Lashing chain systems in compliance with EN 12195-3 will be supplied with:

- Identification-tag
- Manufacturers certificate
- Information for use

Marking:

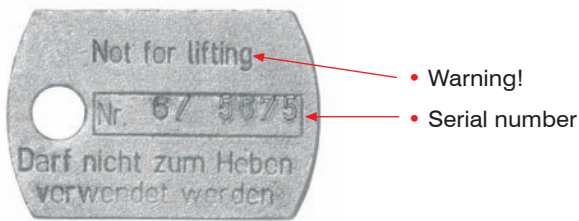

pewag direct lashing table

- This table will enable you to calculate the maximum loading and select the correct lashing assembly to suit a given load. Please note that additional securing devices have not been taken into account in these calculations.
- Each lashing assembly has its own table.
- The calculations for the table are in accordance with EN 12195-1 and take into account the maximum forces generated by acceleration, braking and change of direction.

The tables show the maximum loading when using 4 lashing chain Systems ZRSW and ZKSW.

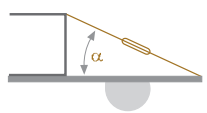
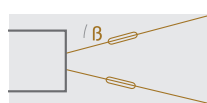
Angle α side view	Max. Load [daN ~ kg]	Dynamic friction factor							
		α	β	0,01	0,1	0,2	0,3	0,4	0,5
	15-35	21-30				17.600	23.450	32.150	49.550
		31-40	8.000	9.750	12.350	15.950	21.050	28.950	44.750
		41-50	6.700	8.300	10.650	13.950	18.100	25.000	38.800
		51-60	5.250	6.650	8.700	11.200	14.650	20.400	31.900
	36-50	21-30			11.800	15.700	21.550	31.300	50.800
		31-40	6.300	8.100	10.750	14.400	19.950	29.150	47.600
		41-50	5.300	6.950	9.400	12.850	17.950	26.500	43.600
		51-60		5.650	7.900	11.000	15.650	23.250	37.850

α vertical angle between lashing and loading area of a load carrier

β longitudinal angle between lashing and longitudinal axis (x-axis) of a load carrier in the plane of the loading area.



How to use the pewag lashing table

First method:

- Determine the dynamic friction factor – please look on page 14.
- Please verify with help of the table if the loading weight with the chosen lashing system at the determined friction factor can be secured. If not please choose a different Lashing system or increase the friction.
- Please verify if the Lashing equipment with the specified angles can be attached. All those angles are possible where the tabular value “Maximum loading” is higher than the real Load.

Example: Lashing = ZRSW 8; Load = steel part; 10 tons; loading area = steel

The dynamic friction factor is 0,2. As shown in the table more combinations of angles with this dynamic friction factor can secure the load of 10 tons with help of a ZRSW 8. Please check now if the Lashing chain can be attached with the recommended angles. Attention: As shown in the table the ZRSW cannot secure the load if the dynamic friction factor is lower. Please make sure that the load and the loading area is clean on the contact surface. Soil can reduce the friction.

Second method:

- Determine the dynamic friction factor – please look on page 14.
- Determine the possible angles for securing the load on the carrier.
- Check with help of the table if with the determined dynamic friction factor and angles the load can be secured safely. If not please choose a stronger lashing system.

Example: Lashing = ZRSW 8, Load = steel part, 10 tons, loading area = steel, two lashing points with possible angles, Lashing point 1 alpha = 31°, beta = 56°, Lashing point 2: alpha = 21°, beta = 31°.

The dynamic friction factor is 0,2. At the angles from Lashing point 1 the maximum loading weight is 8.700 daN. This lashing point is not allowed to be used with a ZRSW 8. At lashing point 2 the max. loading weight is 12.350 daN. This lashing point can be used. Attention: Please make sure that the Lashing point capacity is high enough!

Friction factors

According annex of EN 12195-1

■ Dynamic friction factors of some common loads

Combination of materials in the contact surface	Friction factor μ_D
Sawn wood	
Sawn wood against fabric base laminate/plywood	0,35
Sawn wood against grooved aluminium	0,3
Sawn wood against steel sheets	0,3
Sawn wood against crimped foils	0,2
Crimped foils	
Crimped foils against fabric base laminate/plywood	0,3
Crimped foils against grooved aluminium	0,3
Crimped foils against steel sheets	0,3
Crimped foils against crimped foils	0,3
Cardboard boxes	
Cardboard box against cardboard box	0,35
Cardboard box against wood pallet	0,35
Large bags	
Large bags against wood pallet	0,3
Steel and metal sheets	
Oiled metal sheets against oiled metal sheets	0,1
Flat steel bars against sawn wood	0,35
Unpainted rough steel sheets against sawn wood	0,35
Painted rough steel sheets against sawn wood	0,35
Unpainted rough steel sheets against unpainted rough steel sheets	0,3
Painted rough steel sheets against painted rough steel sheets	0,2
Painted steel barrel against painted steel barrel	0,15
Concrete	
Wall on wall without intermediate layer (concrete/concrete)	0,5
Finished part with wooden intermediate layer on wood (concrete/wood/wood)	0,4
Ceiling on ceiling without intermediate layer (concrete/lattice girder)	0,6
Steel frame with wooden intermediate layer (steel/wood)	0,4
Ceiling on steel frame with wooden intermediate layer (concrete/wood/steel)	0,45
Palettes	
Resin bonded plywood, smooth – Europallet (wood)	0,2
Resin bonded plywood, smooth – box pallet (steel)	0,25
Resin bonded plywood, smooth – plastic pallet (PP)	0,2
Resin bonded plywood, smooth – wooden pressboard pallets	0,15
Resin bonded plywood, sleeve structure – Europallet (wood)	0,25
Resin bonded plywood, sleeve structure – box pallet (steel)	0,25
Resin bonded plywood, sleeve structure – plastic pallet (PP)	0,25
Resin bonded plywood, sleeve structure – wooden pressboard pallets	0,2
Aluminium beams in the load-carrying platform (punched bars) – Europallet (wood)	0,25
Aluminium beams in the load-carrying platform (punched bars) – box pallet (steel)	0,35
Aluminium beams in the load-carrying platform (punched bars) – plastic pallet (PP)	0,25
Aluminium beams in the load-carrying platform (punched bars) – wooden pressboard pallets	0,2

- Friction factor according EN 12195-1
- Values are valid for clean surfaces and optimal conditions
- Please consider that soiling, ice and moisture reduce the friction factor. Please also consider that this can happen during the transport depending on the season.
- Please choose only such values that you can rely on. In case of doubt take the lower value. This is for your own safety.

Information for use (translated version), storage and maintenance of pewag lashing chain systems ■

1. General

Pewag lashing chain systems have been developed for securing loads during transport. Lashing chain systems should be used only by trained personnel. If properly used, pewag lashing chain systems have a long service life and offer a high level of safety. Personal injury and damage to property could result from improper use. It is therefore highly important that you read and understand this user information and act in a responsible and forward-thinking manner when using lashing equipment.

We offer guidelines for the selection and proper usage of lashing chain systems, but sufficient experience about load securing and use of lashing equipment is necessary.

Pewag lashing chain systems to EN 12195-1 & 3 should be assembled and inspected by a competent person.

2. Limitation on use

When assembling or repairing pewag lashing chain systems use only use original pewag parts (e.g. bolts, safety pins, screws, etc.).

Single parts and complete lashing chain systems must not be modified – e.g. bending, grinding, separating individual parts, drilling, etc.. A void heating of the chains to more than 200°C (W inner 200). Do not remove any safety components, such as latches, safety pins, safety catches, etc.

Do not apply any surface coatings to pewag lashing chain systems, i.e. do not subject them to hot galvanising or electrogalvanising. Dipping or removing the coating with chemicals is also dangerous and must be approved by pewag. If required please contact our technical department who will be pleased to provide information.

3. Storage

pewag lashing chain systems should be stored in a clean and dried condition and protected from corrosion, e.g. lightly lubricated.

4. Inspection and tests

Before using any lashing equipment for the first time, it should be ensured that:

- the lashing chain system corresponds exactly to the order;
- the inspection certificate or certificate of conformity has been supplied
- Marking and lashing capacity stated on the ID-tag of the lashing chain system correspond to the information given on the manufacturers certificate
- Records for the lashing chain system exists
- Instructions for the proper use of lashing chain system have been supplied, read and understood by all personnel who are to use the equipment

Before use:

- Inspect lashing chain systems before use for visible damage or signs of wear. In case of doubt or damage do not use the lashing chains and have them inspected by a competent person.

Periodic thorough examinations:

Examination by a competent person according to national regulations, at least every 12 months. Depending on use this period can be shorter; e.g. frequent and rough usage.

After unusual events, that could cause impairment to the lashing chain, it must be checked by a competent person (e.g. after exposure to uncontrolled heat, emergency braking).

Information for use, storage and maintenance of pewag lashing chain systems

4.1. Elimination criteria following visual inspection

- Broken parts
- Missing or illegible marking of the ID tag of the lashing chain system
- Deformation of accessories or the chain itself
- Elongation of the chain. The chain must be discarded if $t > 1,05 t_n$ according to the catalogue
- Wear is determined as the mean value of two measurements of diameters d_1 and d_2 carried out at right angle (see picture). The chain must be discarded if:

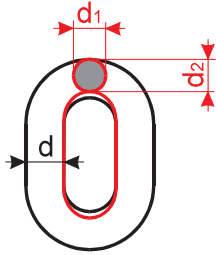

$$\frac{d_1 + d_2}{2} \leq 0,9 d \quad \text{according to the catalogue.}$$

- Cuts, notches, grooves, surface cracks, excessive corrosion, discoloration due to heat, signs of subsequent welding, bent or twisted links or other flaws.
- Missing or damaged safety device (safety catches if fitted) as well as signs of widening or twisting of hooks, i.e. noticeable enlargement of the opening or other forms of deformation. The enlargement of the opening must not exceed 10 % of the nominal value.

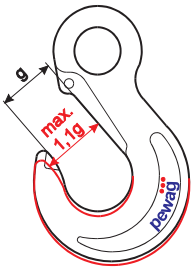

Maximum approved dimensional change:

designation	dimension	admissible deviation
chain	d m	-10%
	t	+5%
links	d	-15%
	t	+10%
hooks*	e	+5%
	d2 and h	-10%
	g	+10%
CW	e	+5%
	c	-10%
Clevis and Connex-pin	d	-10%

* HSW, PSW, KHSW, KVS

4.2 Repair

pewag lashing chain systems should only be repaired by qualified personnel.

4.3 Documentation

Records of inspections, and in particular the results, as well as details of repairs carried out must be kept on file (verification document) during the entire service life of the lashing chain system.

Information for use, storage and maintenance of pewag lashing chain systems

5. Correct use of lashing chain systems

5.1. Restrictions of use due to hazardous or dangerous conditions.

5.1.1. Edge load

The maximum lashing capacity of pewag lashing chain systems was defined on the assumption that the lashing chains are pulled under straight loading, i.e. that they do not run over edges. In the case of edge loading, load protection should be used to avoid damage. If lashing chain systems are to be used without sufficient edge protection the maximum permissible lashing capacity should be reduced, particularly when the danger of breakage is evident. Please consider the relevant reduction load factors from the table below. The lashing capacity is reduced when the maximum permissible load from the pewag lashing table is multiplied with the load reduction factors.

5.1.2. Impact

If the lashing is implemented according to the EN 12195-1 it is not necessary to consider occasional impact loads. These impacts will be counterbalanced because of the shock absorber system of the vehicle and the elasticity of the lashing chain system.

5.1.3. Temperature

pewag lashing chain systems must not be used outside the stated temperature range. In the event of temperatures outside this range, do not use the lashing chain system, and remove it from service. The load reduction factors of the lashing capacity (LC) at high temperatures mentioned in the table are valid as long as the lashing chain system itself has this temperature. After cooling down to room temperature it is no longer necessary to apply the load reduction factors.

5.1.4. Acids, caustics and chemicals



Do not subject pewag lashing chain systems to acid or caustic solutions or use in acid or caustic atmospheres.

5.1.5. Hazardous conditons

The classification of the maximum permissible lashing capacity is valid for normal conditions. In case of potentially hazardous conditions (e.g. restraining of dangerous goods like liquid metals, acidic substances or nuclear materials) a competent person needs to estimate the risk of danger and adapt the permissible lashing capacity.

5.1.6. Use of pewag lashing chain systems for other than the intended purposes

Use pewag lashing chain systems only for the intended purpose of securing the load during transport (not for lifting!). Please contact our technical customer service department if you use the pewag lashing chain system in any other way.

Temperature	-40° – 200°C	Over 200° – 300°C	Over 300° – 400°C
Load factor Winner 200	1	not permissible	not permissible
Load factor Winner 400	1	0,9	0,75
Edge loading Lashing chains	 R=larger than 2x chain ø	 R=larger than chain ø	 R=chain ø or smaller
Load factor	1	0,7	0,5

■ Information for use, storage and maintenance of pewag lashing chain systems

5.2. General information

5.2.1. Lashing points

Choose lashing points so that the angles of the lashing chain system are in the range of our lashing table and that the lashing chain systems are symmetrical with the driving direction. Use only lashing points with adequate strength. Deviation should only be considered after consulting our technical customer service.

5.2.2. Selection

Consider the lashing method required and the load that needs to be secured when selecting the lashing chain systems. Size, form and weight of the load as well as the intended usage category (friction lashing, direct lashing) and the transport environment (additional utilities, lashing points) determine proper selection.

For the securing of heavy loads with the least number of systems, we recommend adopting the direct lashing method wherever possible and using chain lashings due to its high capacity and low elongation.

The number of the lashing systems required should be calculated according to the EN standard 12195-1. In accordance with this standard, pewag has integrated the most commonly used lashing methods in an easy to use lashing table. For more detailed information please see pages 9 - 10.

For the direct lashing method the use of at least two pairs of lashing chain systems are required for stability.

The lashing chain system chosen must have the correct capacity and be of sufficient length for the intended purpose.

In case of doubt safety is a priority rather than overloading the lashing chain system. The connecting parts (hooks, links) of the lashing chain systems must be moveable in the lashing point and adjustable in the tensile direction. Bending stress on the accessories and tip loading of the hooks are not permissible. Hooks must be loaded at the bottom.

Please use either lashing chain systems or lashing straps for the load securing because of the different performance and elongation of different lashing equipment under load (e.g. lashing chains and lashing straps made of synthetic fibre). If required please contact our technical customer service department.

5.2.3. Use

Always consider proper lashing practice. Before lashing, plan the lashing and the release/opening of the lashing system. During a long trip consider possible partial unloading.

Pay attention to overhead lines during loading and unloading. Remove lifting equipment before lashing. The maximum hand force of 50 daN for tightening the tensioning device should only be applied manually. Use of mechanical utilities ie. rods or levers is forbidden. Consider sufficient edge protection. During transport, check the tension of the lashing chain system repeatedly. Before opening the lashing chain system make sure that the load is safe also without securing and the people who unload are not in danger through goods that fall off on toppling down. If necessary assemble the lifting equipment for a possible further transport on the load to avoid a goods falling off or toppling down. Release the lashing chain systems as appropriate so that the load is free standing. Avoid the risk of the lashing chain getting caught during unloading.

■ Examples of lashing chain systems in use (direct lashing)





innovative
safety

Brindley

pewag
austria

Brindley Chains Ltd

1 Tatton Court, Kingsland Grange
Warrington, WA1 4RR

Tel: 01925 825555 Fax: 01925 825338

Email: sales@brindley-chains.co.uk Web: www.brindley-chains.co.uk