

JDN LOW HEADROOM TROLLEYS

The trolley solution for restricted headroom areas.

Carrying capacities: from 0.5 t up to 6.3 t

Where headroom is restricted and standard trolleys can't meet the lifting height requirements we recommend **JDN Low Headroom Trolleys** whereby our air hoists are horizontally mounted. When only very low headroom is available we recommend JDN Ultra-Low Monorail Hoist design.

STANDARD FEATURES

- State of the art design utilising JDN's new PROFI TI motor technology
- Small number of maintenance/wear free moving parts
- No additional motor lubrication required
- 2-step travelling speed
- Adjustable trolley widths to suit your requirements (please contact us for details)

SPECIAL FEATURES

- Able to negotiate curves
- Extended trolley tie bars for bulky or elongated loads

TECHNICAL DATA

Hoist Type Trolley Type		PROFI 05 TI LMF 05-2 t	PROFI 1 TI LMF 05-2 t	PROFI 2 TI LMF 05-2 t	PROFI 3 TI LMF 3.2 t	PROFI 6 TI LMF 6.3 t
Carrying capacity	mt	0.5	1	2	3.2	6.3
Number of chain strands		1	1	2	1	2
Motor output Hoist	kW	1	1	1	3.5	3.5
Motor output Trolley	kW	0.2	0.2	0.2	0.2	0.2
Air pressure	PSI bar	85 6	85 6	85 6	85 6	85 6
Lifting speed at full load	ft/min m/min	32.81 10	16.40 5	8.20 2.5	14.76 4.5	7.21 2.2
Lifting speed without load	ft/min m/min	55.77 17	32.81 10	16.40 5	29.52 9	14.76 4.5
Lowering speed at full load	ft/min m/min	55.77 17	36.09 11	18.04 5.5	35.43 10.8	17.72 5.4
Travelling speed at full load	ft/min m/min	29.53*/45.93 9*/14	29.53*/45.93 9*/14	29.53*/45.93 9*/14	29.53*/45.93 9*/14	29.53*/45.93 9*/14
Air consumption at full load – lifting	cfm m ³ /min	42.38 1.2	42.38 1.2	42.38 1.2	141.26 4	141.26 4
Air consumption at full load – lowering	cfm m ³ /min	52.97 1.5	52.97 1.5	52.97 1.5	194.23 5.5	194.23 5.5
Air consumption trolley motor	cfm m ³ /min	21.19 0.6	21.19 0.6	21.19 0.6	21.19 0.6	21.19 0.6
Air connection		G 1/2	G 1/2	G 1/2	G 3/4	G 3/4
Hose dimension (Ø inside)	inch. mm	0.51 13	0.51 13	0.51 13	0.75 19	0.75 19
Weight with standard lift height and control length	lbs kg	216.05 98	218.26 99	231.59 105	462.97 210	727.53 330
Chain dimension	inch. mm	0.28 x 0.83 7 x 21	0.28 x 0.83 7 x 21	0.28 x 0.83 7 x 21	0.51 x 1.42 13 x 36	0.51 x 1.42 13 x 36
Weight of chain	lbs/m kg/m	2.20 1	2.20 1	2.20 1	8.38 3.8	8.38 3.8
Standard lift	ft m	9.84 3	9.84 3	9.84 3	9.84 3	9.84 3
Length of control at standard lift	ft m	6.56 2	6.56 2	6.56 2	6.56 2	6.56 2
Max. bottom flange thickness t	inch. mm	0.98 25	0.98 25	0.98 25	1.38 35	1.38 35
Max. bottom flange width b	inch. mm	12.20 310	12.20 310	12.20 310	12.20 310	12.20 310
Min. bottom flange width b	inch. mm	3.15 80	3.15 80	3.15 80	4.92 125	4.92 125
Noise level at full load ¹ - lifting	dB(A)	75	76	76	78	78
Noise level at full load ¹ - lowering	dB(A)	78	78	78	80	80

*1st step at F-control with 2-step travelling speed
¹ Measured at 1 m distance acc. to DIN 45635 part 20



Low Headroom Trolley LMF

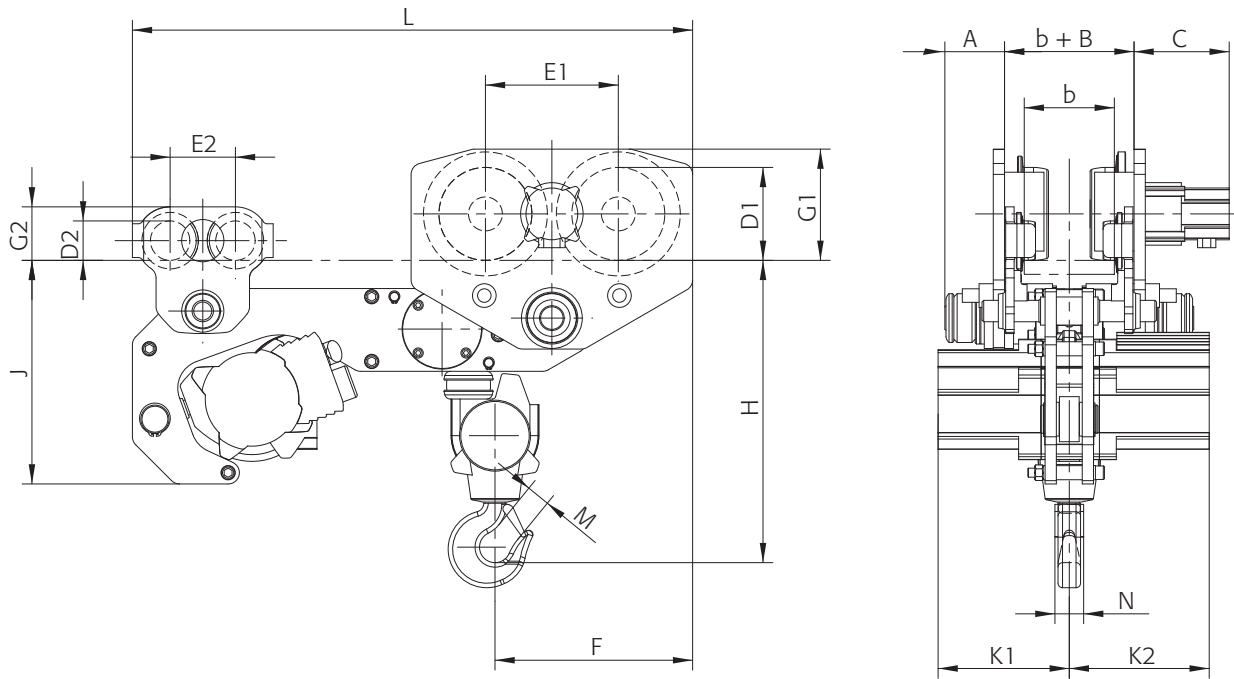

DIMENSIONS

Hoist Type Trolley Type		PROFI 05 TI LMF 05-2 t	PROFI 1 TI LMF 05-2 t	PROFI 2 TI LMF 05-2 t	PROFI 3 TI LMF 3.2 t	PROFI 6 TI LMF 6.3 t
A max.	inch. mm	4.13 105	4.13 105	4.13 105	4.13 105	4.17 106
B	inch. mm	1.42 36	1.42 36	1.42 36	1.42 36	2.76 70
b min.	inch. mm	3.15 80	3.15 80	3.15 80	3.15 80	4.92 125
C	inch. mm	6.46 164	6.46 164	6.46 164	6.46 164	6.65 169
D1	inch. mm	2.76 70	2.76 70	2.76 70	2.76 70	6.50 165
D2	inch. mm	2.76 70	2.76 70	2.76 70	2.76 70	2.76 70
E1	inch. mm	4.57 116	4.57 116	4.57 116	4.57 116	9.29 236
E2	inch. mm	4.57 116	4.57 116	4.57 116	4.57 116	4.57 116
F	inch. mm	6.77 172	6.77 172	7.68 195	8.98 228	13.82 351
G1	inch. mm	3.74 95	3.74 95	3.74 95	3.74 95	7.76 197
G2	inch. mm	3.74 95	3.74 95	3.74 95	3.74 95	3.74 95
H min.	inch. mm	12.60 320	12.60 320	15.51 394	16.34 415	21.14 537
J	inch. mm	12.60 320	12.60 320	12.60 320	15.63 397	15.63 397
K1	inch. mm	5.71 145	5.71 145	5.71 145	9.17 233	9.17 233
K2	inch. mm	5.98 152	5.98 152	5.98 152	9.76 248	9.76 248
L	inch. mm	28.15 715	28.15 715	28.15 715	32.48 825	39.17 995
M	inch. mm	1.10 28	1.10 28	1.10 28	1.18 30	1.57 40
N	inch. mm	1.65 42	1.65 42	1.65 42	1.65 42	2.01 51
t max.	inch. mm	0.98 25	0.98 25	0.98 25	1.38 35	1.38 35

