

Hoisting equipment Ratchet lever hoists

Technical data model PT

Model	EAN-No. 4025092*	Capacity kg	Number of chain falls	Chain dimensions d x p mm	Lift with one full lever turn mm	Handle pull at WLL daN	Net weight at standard lift (3 m) kg
PT 800	*076463	800	1	5.6 x 17.1	24	26	5.5
PT 1600	*076470	1600	1	7.1 x 21.2	23	30	9.6
PT 3200	*076487	3200	1	9 x 27.2	16	38	16.0
PT 6300	*076494	6300	2	9 x 27.2	8	39	31.0

Dimensions model PT

Model	PT 800	PT 1600	PT 3200	PT 6300
Amin., mm	290	330	430	580
B, mm	21	27	36	53
C, mm	24	31	35	46
D, mm	13	20	24	43
E, mm	235	370	370	370
F, mm	120	138	177	259
G, mm	38	41	53	85
H, mm	82	97	124	174
J, mm	142	163	185	185
K, mm	52	65	83	83
L, mm	90	98	102	102

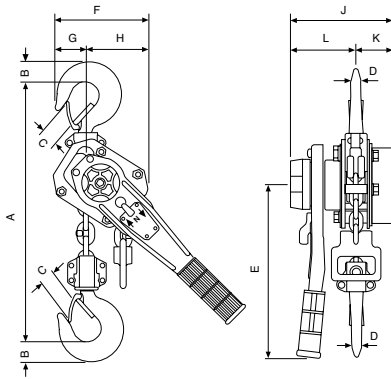

Yale hoists and trolleys are not designed for passenger elevation applications and must not be used for this purpose.

Model PT